



CURRICULUM – 2020

(C-20)

DIPLOMA IN

CIVIL ENGINEERING

State Board of Technical Education & Training
Andhra Pradesh
Amaravathi

CURRICULUM- C 20
FOR
DIPLOMA PROGRAMMES OF SBTET,AP

PREAMBLE

The proposed programme intends to develop a skilled technician to support the industries both nationally or globally. It also helps to kindle the spirit of entrepreneurship with necessary skills and theoretical inputs aligning with the National policy of 'Make in India'. The programme also provides for accomplishing higher education goals for those who wish to enrich their theoretical concepts further.

The State Board of Technical Education and Training, (SBTET) AP, has been offering Diploma programmes to meet the above said aspirations of the stake holders: industries, students, academia, parents and the society at large. As such, it has been the practice of SBTET, A.P., to keep the curriculum abreast with the advances in technology through systematic and scientific analysis of current curriculum and bring out an updated revised version at regular intervals. Accordingly the SBTET, AP under the aegis of the Department of Technical Education, Andhra Pradesh in its 57th Board Meeting held on 05-02-2019 (vide item no: 18) resolved to update the Polytechnic Curriculum C-16 with the guidance of National Institute of Technical Teachers Training & Research (NITTTR), Extension Centre, Vijayawada (ECV), to be implemented with effect from the academic year '20-21.

Analysis of Curriculum C-16 (SWOT analysis) started in the month of June-2019. Feedback was collected from all stake holders: Students, Lecturers, Senior Lecturers, Head of Sections and Principals for all programmes for this purpose. A series of workshops with subject experts followed in the subsequent weeks and the draft curricula were prepared for every programme. Finally, an interactive session with representatives from industries, academia and subject experts was held on 04.01.2020 for thorough perusal and critique of draft curricula; and the suggestions received thus received from Industrialists and academia have been recorded , validated by another set of experienced subject teachers from the Department of Technical education for incorporation into the Curriculum C-20.

The design of new Curricula for the different diploma programmes has thus been finalised with the active participation of the members of the faculty teaching in the Polytechnics of Andhra Pradesh, and duly reviewed by Expert Committee constituted of academicians and representatives from industries. Thus, the primary objective of the curriculum change is to produce employable technicians in the country by correlating the growing needs of the industries with relevant academic input.

The outcome based approach as given by NBA guidelines has been followed throughout the design of this curriculum is designed to meet the requirements of NBA Accreditation, too.

The revised New Curriculum i.e., Curriculum–2020 (C-20) is approved by BoG of SBTET for its implementation with effect from 2020-21.

Highlights of Curriculum C-20:

1. Duration of course for regular Diploma and for sandwich Diploma is 3 years and 3½ years respectively.
2. The Curriculum is prepared in Semester Pattern. However, First Year is maintained as Year-wise pattern.
3. 6 Months Industrial training has been introduced for 3 years Diploma Courses and 1 year Industrial Training is introduced for 3 ½ years Sandwich Diploma courses.
4. Updated subjects relevant to the industry are introduced in all the Diploma courses.
5. CISCO course content has been incorporated into the ECE and CME programmes for certification from CISCO in lieu of industrial training when students are unable to get Industrial Training placement in any industry.
6. The policy decisions taken at the State and Central level with regard to environmental science are implemented by including relevant topics in Chemistry. This is also in accordance with the Supreme Court guidelines issued in Sri Mehta's case.
7. Keeping in view the increased need of communication skills which is playing a major role in the success of Diploma Level students in the Industries, emphasis is given for learning and acquiring listening, speaking, reading and writing skills in English. Further as emphasized in the meetings, Communication Skills lab and Life Skills lab are continuing for all the branches.
8. CAD specific to the branch has been given emphasis in the curriculum. Preparing drawings using CAD software has been given more importance.
9. Upon reviewing the existing C-16 curriculum, it is found that the theory content is found to have more weightage than the Practical content. In C-20 curriculum, more emphasis is given to the practical content in Laboratories and Workshops, thus strengthening the practical skills.
10. With increased emphasis for the student to acquire Practical skills, the course content in all the subjects is thoroughly reviewed and structured as outcome based than the conventional procedure based.
11. Curricula of Laboratory and Workshops have been thoroughly revised based on the suggestions received from the industry and faculty, for better utilization of the equipment available in the Polytechnics. The experiments /exercises that are chosen for the practical sessions are identified to confirm to the field requirements of industry.
12. An exclusive section for assessing Higher order Thinking skills (HOTS) has been introduced in summative evaluation.

Acknowledgements:

It is pertinent to acknowledge the support of the following in the making of Curriculum C-20. A series of workshops in three phases were conducted by NITTTR, AP Extension Centre, Vijayawada involving faculty from Polytechnics, Premier Engineering Colleges & Industries to analyze the Previous C-16 Curriculum and to design C-20 Curriculum under the guidance of Dr C. R. Nagendra Rao, Professor & Head, NITTTR-ECV. The efforts & support extended by NITTTR to bring out final Curriculum C-20 by incorporating needs, aspiration & expectations of all stake holders is highly appreciated and gratefully acknowledged.

The Members of the working group are grateful to Sri M.M. Nayak, I.A.S., Special Commissioner of Technical Education & Chairman of SBTET, AP. and Sri. G. Anantha Ramu, I.A.S., Principal Secretary, Department of Skill Development and Training for their guidance and valuable inputs during process of revising, modifying and updating the Curriculum C-20. The Members acknowledge with thanks the guidance & inspiration provided by Sri. V.S. Dutt, Secretary, SBTET, Andhra Pradesh and other officials of Directorate of Technical Education

and the State Board of Technical Education, Andhra Pradesh, experts from industry, academia from the universities and higher learning institutions and all teaching fraternity from the Polytechnics who are directly or indirectly involved in preparation of the curricula.

RULES AND REGULATIONS OF C-20 CURRICULUM

1 DURATION AND PATTERN OF THE COURSES

All the Diploma programs run at various institutions are of AICTE approved 3 years or 3½ years duration of academic instruction.

All the Diploma courses are run on year wise pattern in the first year, and the remaining two or two & half years are run in the semester pattern. In respect of few courses like Diploma in Bio-Medical course, the training will be in the seventh semester. Run-through system is adopted for all the Diploma Courses, subject to eligibility conditions.

2 PROCEDURE FOR ADMISSION INTO THE DIPLOMA COURSES:

Selection of candidates is governed by the Rules and Regulations laid down in this regard from time to time.

- a) Candidates who wish to seek admission in any of the Diploma courses will have to appear for the Common Entrance Test for admissions into Polytechnics (POLYCET) conducted by the State Board of Technical Education and Training, Andhra Pradesh, Vijayawada.
Only the candidates satisfying the following requirements will be eligible to appear for the Common Entrance Test for admissions into Polytechnics (POLYCET).
- b) The candidates seeking admission should have appeared for S.S.C examination, conducted by the Board of Secondary Education, Andhra Pradesh or equivalent examination thereto, at the time of applying for the Common Entrance Test for admissions into Polytechnics (POLYCET). In case of candidates whose results of their Qualifying Examinations is pending, their selection shall be subject to production of proof of their passing the qualifying examination in one attempt or compartmentally at the time of admission.
- c) Admissions are made based on the merit obtained in the Common Entrance Test (POLYCET) and the reservation rules stipulated by the Government of Andhra Pradesh from time to time.
- d) For admission into the following Diploma Courses for which entry qualification is 10+2, candidates need not appear for POLYCET. A separate notification will be issued for admission into these courses.
 - i). D.HMCT ii).D. Pharmacy

3 MEDIUM OF INSTRUCTION

The medium of instruction and examination shall be English.

4 PERMANENT IDENTIFICATION NUMBER (PIN)

A cumulative / academic record is to be maintained of the Marks secured in sessional work and end examination of each year for determining the eligibility for promotion etc., A Permanent Identification Number (PIN) will be allotted to each admitted candidate to maintain academic records.

5 NUMBER OF WORKING DAYS PER SEMESTER / YEAR:

- a) The Academic year for all the Courses shall be in accordance with the Academic Calendar.
- b) The Working days in a week shall be from Monday to Saturday
- c) There shall be 7 periods of 50 minutes duration each on all working days.
- d) The minimum number of working days for each semester / year shall be 90 / 180 days excluding examination days. If this prescribed minimum is not achieved due to any reason, special arrangements shall be made to conduct classes to complete the syllabus.

6 ELIGIBILITY (ATTENDANCE TO APPEAR FOR THE END EXAMINATION)

- a) A candidate shall be permitted to appear for the end examination in all subjects, if he or she has attended a minimum of 75% of working days during the year/Semester.
- b) Condonation of shortage of attendance in aggregate up to 10% (65% and above and below 75%) in each semester or 1st year may be granted on medical grounds.
- c) A stipulated fee shall be payable towards condonation for shortage of attendance.
- d) Candidates having less than 65% attendance shall be detained.
- e) Students whose shortage of attendance is not condoned in any semester / 1st year and not paid the condonation fee in time are not eligible to take their end examination of that class and their admissions shall stand cancelled. They may seek re-admission for that semester / 1st year when offered in the next subsequent academic semester/year.
- f) For INDUSTRIAL TRAINING:
 - i) During Industrial Training the candidate shall put in a minimum of 90% attendance.
 - ii) If the student fails to secure 90% attendance during industrial training, the student shall reappear for 6 months industrial training at his own expenses.

7 READMISSION

Readmission shall be granted to eligible candidates by the respective Principal/ Regional Joint Director.

- a) (i) Within 15 days after commencement of class work in any semester (Except Industrial Training).
- (ii) For Industrial Training: before commencement of the Industrial training.
- b) Within 30 days after commencement of class work in any year (including D. Pharmacy course or first year course in Engineering and Non Engineering Diploma streams).
Otherwise such cases shall not be considered for readmission for that semester / year and are advised to seek readmission in the next subsequent eligible academic year.
The percentage of attendance of the readmitted candidates shall be calculated from the first day of beginning of the regular class work for that year / Semester, as officially announced by CTE/SBTET but not from the day on which he/she has actually reported to the class work.

8 SCHEME OF Evaluation

a) First Year

THEORY Courses: Each Course carries Maximum marks of 80 with examination of 3 hours duration, along with internal assessment for Maximum of 20 marks. (Sessional marks). However, there are no minimum marks prescribed for sessionals.

Laboratory Courses: There shall be 40 Marks for internal assessment i.e. sessional marks for each practical Course with an end examination of 3 hours duration carrying 60 marks. However, there are no minimum marks prescribed for sessionals.

b) III, IV, V, VI and VII Semesters:

THEORY Courses: End semester evaluation shall be of 3 hours duration and for a maximum of 80 marks.

Laboratory Courses: Each Course carry 60/30 marks of 3hours duration 40/20 sessional marks.

9 INTERNAL ASSESSMENT SCHEME

- a) **Theory Courses:** Internal assessment shall be conducted for awarding sessional marks on the dates specified. **Three unit tests shall be conducted for I year students and two Unit Tests for semesters.**

Internal Assessment shall be of 90 minutes duration and for a maximum of 40 marks.

For each test

The average of marks of all the test, reduced to 20 shall be taken as final sessional in any case.

- b) **Practical Courses:**

(i) **Drawing Courses:**

The award of sessional marks for internal Assessment shall be as given in the following table

Distribution of Marks for the Internal Assessment Marks			
First Year (Total:40 Marks)		Semesters (Total:40 Marks)	
Max:20 Marks	Max:20 Marks	Max:20 Marks	Max:20 Marks
From the Average of THREE Unit Tests.	From the Average of Assessment of Regular Class work Exercises.	From the Average of TWO Unit Tests.	From the Average of Assessment of Regular Class work Exercises.

All Drawing exercises are to be filed in **serial order** and secured for further scrutiny by a competent authority

(ii) Laboratory Courses:

Student's performance in Laboratories / Workshop shall be assessed during the year/ semester of study for 40 marks in each practical Course.

Evaluation for Laboratory Courses, other than Drawing courses:

- i. Instruction (teaching) in laboratory courses (except for the course on Drawing) here after shall be task/competency based as delineated in the Laboratory sheets, prepared by SBTET, AP & NITTTR- ECV and posted in SBTET website.
 - ii. Internal assessment for Laboratory shall be done on the basis of task/s performed by the student as delineated in the laboratory sheets, prepared by SBTET, AP & NITTTR- ECV and posted in AP, SBTET website.
 - iii. Question paper for End semester Evaluation shall also be task/s based and shall be prepared and distributed by SBTET as done in case of theory courses be prepared as per SBTET rules in vogue.
- c) Internal assessment in Labs / workshops / Survey field work etc., during the course of study shall be done and sessional marks shall be awarded by the concerned Teacher.
- d) For practical examinations, except in drawing, there shall be two examiners. External examiner shall be appointed by the Principal in consultation with respective Head of Section preferably choosing a qualified person from in the order of preference.
- i) Nearby Industry
 - ii) Govt / Semi Govt organization like R & B, PWD, PR, Railways, BSNL, APSRTC, APSEB etc.,
 - iii) Govt / University Engg College.
 - iv) HoDs from Govt. Polytechnic
- Internal examiner shall be the person concerned with internal assessment as in (c) above. The end examination shall be held along with all theory papers in respect of drawing.
- e) Question Paper for Practicals: Question paper should cover (the experiments / exercise prescribed to test various) skills like handling, manipulating, testing, trouble shooting, repair, assembling and dismantling etc., from more than one experiment / exercise
- f) Records pertaining to internal assessment marks of both theory and practical Courses are to be maintained for official inspection.

g) In case of Diploma programs *having* Industrial Training, Internal Assessment and Summative Evaluation, shall be done as illustrated in the following table:

Assessment no	Upon completion of	By	Based on	Max Marks
1	12 weeks	1.The faculty concerned and 2. Training Mentor of the industry	Learning outcomes as given in the scheme of assessment ,for Industrial Training	120
2	20-22 weeks			120
3.Final summative Evaluation	23 week	1.The faculty member concerned, 2.HoD concerned and 3.An external examiner	1.Demonstration of any one of the skills listed in learning outcomes	30
			2.Training Report	20
			3.Viva Voce	10
TOTAL				300

10 MINIMUM PASS MARKS

THEORY EXAMINATION:

For passing a theory Course, a candidate has to secure a minimum of 35% in end examination and a combined minimum of 35% of both Sessional and end examination marks put together.

PRACTICAL EXAMINATION:

For passing a practical Course, a candidate has to secure a minimum of 50% in end examination and a combined minimum of 50% of both sessional and practical end examination marks put together. In case of D.C.C.P., the pass mark for typewriting and short hand is 45% in the end examination. There are no sessional marks for typewriting and Shorthand Courses of D.C.C.P course.

INDUSTRIAL ASSESSMENT:

Pass marks is 50% in assessment at Industry (I and II assessments put together) and also 50% in final summative assessment at institution level

11. PROVISION FOR IMPROVEMENT

Improvement is allowed only after he / she has completed all the Courses from First Year to Final semester of the Diploma.

- Improvement is allowed in any 4 (Four) Courses of the Diploma.
- The student can avail of this improvement chance **ONLY ONCE**, that too within the succeeding two examinations after the completion of Diploma. However, the duration

including Improvement examination shall not exceed **FIVE** years from the year of first admission.

- c) No improvement is allowed in Practical / Lab Courses or Project work or Industrial Training assessment. However, improvement in drawing Course(s) is allowed.
- d) If improvement is not achieved, the marks obtained in previous Examinations hold good.
- e) Improvement is not allowed in respect of the candidates who are punished under Mal-practice in any Examination.
- f) Examination fee for improvement shall be paid as per the notification issued by State Board of Technical Education and Training from time to time.
- g) All the candidates who wish to appear for improvement of performance shall deposit the original Marks Memos of all the years / Semesters and also original Diploma Certificate to the Board. If there is improvement in performance of the current examination, the revised Memorandum of marks and Original Diploma Certificate will be issued, else the submitted originals will be returned.

12. RULES OF PROMOTION FROM 1ST YEAR TO 3RD, 4TH, 5TH, 6TH and 7TH SEMESTERS:

A) For Diploma Courses of 3 Years duration

- i. A candidate shall be permitted to appear for first year examination provided he / she puts in 75% attendance (which can be condoned on Medical grounds upto 10%) i.e. attendance after condonation on Medical grounds should not be less than 65% and pay the examination fee.
- ii. A candidate shall be promoted to 3rd semester if he/she puts the required percentage of attendance in the first year and pays the examination fee. A candidate who could not pay the first year examination fee has to pay the promotion fee as prescribed by State Board of Technical Education and Training, AP from time to time before commencement of 3rd semester.
- iii. A candidate shall be promoted to 4th semester provided he/she puts the required percentage of attendance in the 3rd semester and pay the examination fee. A candidate, who could not pay the 3rd semester exam fee, has to pay the promotion fee as prescribed by State Board of Technical Education and Training AP from time to time before commencement of 4th semester.

A candidate is eligible to appear for the 4th semester examination if he/she

- a) Puts the required percentage of attendance in the 4th semester
- b) Should not have failed in more than four Courses in 1st year

For IVC & ITI Lateral Entry Students:

- a) A candidate is eligible to appear for the 4th semester examination if he/she puts the required percentage of attendance in the 4th semester
- b) A candidate is eligible to appear for the 4th semester examination if he/she clears at least two Courses in third semester.
- iv) A candidate shall be promoted to 5th semester provided he / she puts the required percentage of attendance in the 4th semester and pays the examination fee. A candidate, who could not pay the 4th semester examination fee, has to pay the

promotion fee as prescribed by State Board of Technical Education and Training from time to time before commencement of 5th semester.

A candidate is eligible to appear for the 5th semester examination if he/she

- a) Puts the required percentage of attendance in the 5th semester
- b) Should get eligibility to appear for 4th Semester examination.

The first backlog exam in 5th semester will be conducted only in instant/supplementary diploma examination.

For IVC& ITI Lateral Entry students:

- a) Puts the required percentage of attendance in the 5th semester
- v) A candidate shall be sent to Industrial training provided he/she puts in the required percentage of attendance in the 4th semester and pay the examination fee/ promotion fee as prescribed by SBTET.

A candidate is eligible to appear for Industrial Training assessment (Seminar/Viva-voce)

- a) Puts the required percentage of attendance, ie., 90% in 6th semester Industrial Training

For IVC & ITI Lateral Entry students:

- a) Puts the required percentage of attendance, ie., 90% in 6th semester Industrial Training.
- b) should get eligibility to appear for 5th Semester Examination.

B) For Diploma Courses of 3 ½ Years duration (MET/ CH/ CHPP/ CHPC/ CHOT/ TT):

- i. A candidate shall be permitted to appear for 1st year examination provided he / she puts in 75% attendance (which can be condoned on Medical grounds upto 10%) i.e. attendance after condonation on Medical grounds should not be less than 65% and pay the examination fee.
- ii. A candidate shall be promoted to 3rd semester if he/she puts the required percentage of attendance in the 1st year and pays the examination fee. A candidate who could not pay the 1st year examination fee has to pay the promotion fee as prescribed by State Board of Technical Education and Training from time to time before commencement of 3rd semester.
- iii. A candidate shall be promoted to 4th semester provided he/she puts the required percentage of attendance in the 3rd semester and pay the examination fee. A candidate, who could not pay the 3rd semester exam fee, has to pay the promotion fee as prescribed by State Board of Technical Education and Training from time to time before commencement of 4th semester.

A candidate is eligible to appear for the 4th semester exam if he/she

- a). Puts the required percentage of attendance in the 4th semester
- b). Should not have failed in more than Four backlog Courses of 1st year.

For IVC & ITI Lateral Entry students:

- a) Puts the required percentage of attendance in the 4th semester
- iv. A candidate shall be promoted to 5th semester industrial training provided he / she puts the required percentage of attendance in the 4th semester and pays the examination fee. A candidate, who could not pay the 4th semester examination fee, has to pay the promotion fee as prescribed by State Board of Technical Education and Training from time to time before commencement of 5th semester.
- v. Promotion from 5th to 6th semester is automatic (i.e., from 1st spell of Industrial Training to 2nd spell) provided he/she puts the required percentage of attendance, which in this case i.e., 90 % of attendance and attends for the VIVA-VOCE examination at the end of training.
- vi. A candidate shall be promoted to 7th semester provided he / she puts the required percentage of attendance in the 6th semester and pays the examination fee. A candidate, who could not pay the 6th semester examination fee, has to pay the promotion fee as prescribed by State Board of Technical Education and Training from time to time before commencement of 7th semester.
- vii. A candidate shall be promoted to 7th semester of the course provided he/she has successfully completed both the spells of Industrial Training.

A candidate is eligible to appear for 7th semester examination if he/she

- a) Puts in the required percentage of attendance in the 7th semester
- b) Should get eligibility to appear for 4th semester Examination.

For IVC & ITI Lateral Entry students:

- a) Puts in the required percentage of attendance in the 7th semester
- b) Should not have failed more than four backlog Courses of 3rd Semester

C) For Diploma Courses of 3 ½ Years duration (BM):

The same rules which are applicable for conventional courses also apply for this course. The industrial training in respect of this course is restricted to one semester (6 months) after the 6th semester (3 years) of the course.

- i. A candidate shall be permitted to appear for first year examination provided he / she puts in 75% attendance (which can be condoned on Medical grounds upto 10%) i.e. attendance after condonation on Medical grounds should not be less than 65% and pay the examination fee.
- ii. A candidate shall be promoted to 3rd semester if he/she puts the required percentage of attendance in the first year and pays the examination fee. A candidate who could not pay the first year examination fee has to pay the promotion fee as prescribed by State Board of Technical Education and Training from time to time before commencement of 3rd semester.
- iii. A candidate shall be promoted to 4th semester provided he/she puts the required percentage of attendance in the 3rd semester and pay the examination fee. A candidate who could not pay the 3rd semester examination fee, has to pay the promotion fee as prescribed by State Board of Technical Education and Training from time to time before commencement of 4th semester.

- A candidate is eligible to appear for the 4th semester examination if he/she
- a) Puts in the required percentage of attendance in the 4th semester
 - b) Should not have failed in more than Four backlog Courses of 1st year

For IVC & ITI Lateral Entry Students:

A candidate is eligible to appear for the 4th semester examination if he/she puts the required percentage of attendance in the 4th semester

- iv. A candidate shall be promoted to 5th semester provided he / she puts the required percentage of attendance in the 4th semester and pays the examination fee. A candidate, who could not pay the 4th semester examination fee, has to pay the promotion fee as prescribed by State Board of Technical Education and Training from time to time before commencement of 5th semester.

A candidate is eligible to appear for the 5th semester exam if he/she

- a) Puts in the required percentage of attendance in the 5th semester.
- b) Should get eligibility to appear for 4th Semester examination.

For IVC & ITI Lateral Entry students:

- a) Puts in the required percentage of attendance in the 5th semester.
- b) Should not have failed in more than Four backlog Courses of 3rd Semester.

- v. A candidate shall be promoted to 6th semester provided he/she puts in the required percentage of attendance in the 5th semester and pays the examination fee. A candidate who could not pay the 5th semester examination fee, has to pay the promotion fee as prescribed by State Board of Technical Education and Training from time to time before commencement of 6th semester.

A candidate is eligible to appear for 6th semester examination

- a) Puts in the required percentage of attendance in 6th semester and
- b) should get eligibility to appear for 4th Semester Examination.

For IVC & ITI Lateral Entry students:

- a) Puts in the required percentage of attendance in 6th semester.
- b) Should get eligibility to appear for 5th Semester Examination.

- vi. A candidate shall be promoted to 7th semester provided he/she puts in the required percentage of attendance in 6th semester and pay the examination fee. A candidate, who could not pay the 6th semester examination fee, has to pay the promotion fee prescribed by SBTET from time to time before commencement of the 7th semester (Industrial Training).

A candidate is eligible to appear for 7th semester Industrial Training assessment (Seminar/Viva-voce) if he/she

- a) Puts in the required percentage of attendance, ie., 90% in 7th semester Industrial Training
- b) Should get eligibility to appear for 4th Semester Examination.

For IVC & ITI Lateral Entry students:

- a) Puts in the required percentage of attendance, ie., 90% in 7th semester Industrial Training.
- b) Should get eligibility to appear for 5th Semester Examination.

Important Note:

Seminar/Viva-voce should not be conducted for Not-Eligible Candidates, till the candidate gets eligibility. However, the record of internal Assessment for Industrial Training for 260 marks shall be maintained at Institution Level for all candidates and the data is to be uploaded only for eligible candidates. For not eligible candidates the data is to be uploaded as and when the candidate gets eligibility.

OTHER DETAILS

- a) In case a candidate does not successfully complete the Industrial training, he / she will have to repeat the training at his / her own cost.
- b) The First spell of Industrial training shall commence 10 days after the completion of the last theory examination of 4th Semester.
- c) The Second spell of Industrial training shall commence within 10 days after the completion of first spell of Industrial training.

13. STUDENTS PERFORMANCE EVALUATION

Successful candidates shall be awarded the Diploma under the following divisions of pass.

- a) First Class with Distinction shall be awarded to the candidates who secure an overall aggregate of 75% marks and above.
- b) First Class shall be awarded to candidates who secure overall aggregate of 60% marks and above and below 75% marks.
- c) Second Class shall be awarded to candidates who secure a pass with an overall aggregate of below 60%.
 - i. The Weightage of marks for various year/Semesters which are taken for computing overall aggregate shall be 25% of I year marks + 100% of 3rd and subsequent Semesters.
 - ii. In respect IVC & ITI Lateral Entry candidates who are admitted directly into diploma course at the 3rd semester (i.e., second year) level the aggregate of (100%) marks secured at the 3rd and subsequent semesters of study shall be taken into consideration for determining the overall percentage of marks secured by the candidates for award of class/division.
- d) Second Class shall be awarded to all students, who fail to complete the Diploma in the regular 3 years/ 3 ½ years and four subsequent examinations, from the year of first admission.

14. EXAMINATION FEE SCHEDULE:

The examination fee should be as per the notification issued by State Board of Technical Education and Training, AP from time to time.

15. STRUCTURE OF EXAMINATION QUESTION PAPER:

I. Formative assessment (Internal examination)

a) For theory Courses:

Three unit tests for first year and two unit tests for semesters shall be conducted with a duration of 90 minutes for each test for maximum marks of 40. It consists of part A and Part B.

Part A contains five questions and carries 16 marks. Among these five questions first question consists of four objective items like one word or phrase answer/filling-in the blanks/true or false etc with one mark for each question. The other four questions are short answer questions and carry three marks each.

Part B carries 24 marks and consists of three questions with internal choice ie., Either/Or type , and each question carries 8 marks.

The sum of marks of 3 tests for 1 year and 2 tests for semesters shall be reduced to 20 marks in each Course for arriving at final sessional marks.

b) For drawing Courses:

For 1 year:

Three unit tests with duration of 90 minutes and for maximum marks of 40 marks shall be conducted for first year. It consists of part A and Part B.

Part A consists four questions for maximum marks of 16 and each question carries four marks (4×4 marks=16 marks).

Part B carries maximum marks of 24 and consists of five questions while the student shall answer any three questions out of these five questions. Each question in this part carries a maximum marks of 8, (3×8 marks=24 marks).

The sum of marks obtained in 3 unit test marks shall be reduced to 20 marks for arriving at final sessional marks. Remaining 20 marks are awarded by the Course teacher based on the student's performance during regular class exercise.

For semester: Two unit tests with duration of 90 minutes and for maximum marks of 40 marks shall be conducted. The sum of marks obtained in 2 unit test marks shall be reduced to 20 marks for arriving at final sessional marks. Remaining 20 marks are awarded by the Course teacher based on the student's performance during regular class exercise

c) For Laboratory /workshop: 50% of total marks for the Course shall be awarded based on continuous assessment of the student in laboratory/workshop classes and the remaining 50% shall be based on the sum of the marks obtained by the students in two tests.

II. Summative assessment (End examination)

The question paper for theory examination is patterned in such a manner that the Weightage of periods/marks allotted for each of the topics for a particular Course be considered. End Examination paper is of 3 hours duration.

a) Each theory paper consists of Section 'A', 'B' and 'C'.

Section 'A' with Max marks of 30, contains 10 short answer questions. All questions are to be answered and each carries 3 marks, i.e., $10 \times 3 = 30$.

Section 'B' with Max marks of 40 contains 5 essay type questions including Numerical questions (without any divisions in the question), with internal choice (Either/or type), each carrying 8 marks, i.e., Max. Marks: $5 \times 8 = 40$.

Section 'C' with Max marks of 10 contains single essay type, Higher order Thinking skills question (HoTs) including Numerical questions, without choice (without any divisions in the question),

Thus the total marks for theory examination shall be: 80.

b) For Engineering Drawing Course (107) consist of section 'A' and section 'B'.

Section 'A' with max marks of 20, contains four (4) questions. All questions in section 'A' are to be answered to the scale and each carries 5 marks, ie. $4 \times 5 = 20$.

Section 'B' with max marks of 40, contains six (6) questions. The student shall answer any four (4) questions out of the above six questions and each question carries 10 Marks, ie. $4 \times 10 = 40$.

c) Practical Examinations

For Workshop practice and Laboratory Examinations, Each student has to pick up a question paper distributed by Lottery System.

Max. Marks for an experiment / exercise : 50

Max. Marks for VIVA-VOCE : 10

Total Max. Marks : 60

In case of practical examinations with 50 marks, the marks shall be distributed as

Max. Marks for an experiment / exercise : 25

Max. Marks for VIVA-VOCE : 05

Total Max. Marks : 30

In case of any change in the pattern of question paper, the same shall be informed sufficiently in advance to the candidates.

d) Note: Evaluation for Laboratory Courses, other than Drawing courses:

- I. Instruction (teaching) in laboratory courses (except for the course on Drawing) hereafter shall be task/competency based as delineated in the Laboratory sheets, prepared by SBTET, AP and posted in its website.
- II. Internal assessment for Laboratory shall be done on basis of task/s performed by the student as delineated in the laboratory sheets, prepared by SBTET, AP and posted in its website.
- III. Question paper for End semester Evaluation shall be prepared as per SBTET rules in vogue.

16. ISSUE OF MEMORANDUM OF MARKS

All candidates who appear for the end examination will be issued memorandum of marks without any payment of fee. However candidates who lose the original memorandum of marks have to pay the prescribed fee to the Secretary, State Board of Technical Education and Training, A.P. for each duplicate memo from time to time.

17. MAXIMUM PERIOD FOR COMPLETION OF DIPLOMA Programmes:

Maximum period for completion of the diploma courses is twice the duration of the course from the date of First admission (includes the period of detention and discontinuation of studies by student etc) failing which they will have to forfeit the claim for qualifying for the award of Diploma (They will not be permitted to appear for examinations after that date). This rule applies for all Diploma courses of 3 years and 3 ½ years of engineering and non-engineering courses.

18. ELIGIBILITY FOR AWARD OF DIPLOMA

A candidate is eligible for award of Diploma Certificate if he / she fulfil the following academic regulations.

- i. He / She pursued a course of study for not less than 3 / 3 ½ academic years & not more than 6 / 7 academic years.
- ii. He / she have completed all the Courses.
Students who fail to fulfil all the academic requirements for the award of the Diploma within 6 / 7 academic years from the year of admission shall forfeit their seat in the course & their seat shall stand cancelled.

For IVC & ITI Lateral Entry students:

- i. He / She pursued a course of study for not less than 2 / 2 ½ academic years & not more than 4 / 5 academic years.
- ii. He / she has completed all the Courses.
Students who fail to fulfill all the academic requirements for the award of the Diploma within 4 / 5 academic years from the year of admission shall forfeit their seat in the course & their seat shall stand cancelled.

19. ISSUE OF PHOTO COPY OF VALUED ANSWER SCRIPT, RECOUNTING& REVERIFICATION:

A) FOR ISSUE OF PHOTO COPIES OF VALUED ANSWER SCRIPTS

- I. A candidate desirous of applying for Photo copy of valued answer script/s should apply within prescribed date from the date of the declaration of the result.
- II. Photo copies of valued answer scripts will be issued to all theory Courses and Drawing Course(s).
- III. The Photo copy of valued answer script will be dispatched to the concerned candidate's address as mentioned in the application form by post.
- IV. No application can be entertained from third parties.

B) FOR RE-COUNTING(RC) and RE-VERIFICATION(RV) OF THE VALUED ANSWER SCRIPT

- i. A candidate desirous of applying for Re-verification of valued answer script should apply within prescribed date from the date of the declaration of the result.
- ii. Re-verification of valued answer script shall be done for all theory Courses' and Drawing Course(s).
- iii. The Re-verification committee constituted by the Secretary, SBTETAP with Course experts shall re-verify the answer scripts.

I. RE-COUNTING

The Officer of SBTET will verify the marks posted and recount them in the already valued answer script. The variations if any will be recorded separately, without making any changes on the already valued answer script. The marks awarded in the original answer script are maintained (hidden).

II. RE-VERIFICATION

- (i) The Committee has to verify the intactness and genuineness of the answer script(s) placed for Re-verification.
- (ii) Initially single member shall carry out the re-verification.
- (iii) On re-verification by single member, if the variation is less than 12% of maximum marks, and if there is no change in the STATUS in the result of the candidate, such cases will not be referred to the next level ie., for 2-Tier evaluation.
- (iv) On re-verification by a single member, if the variation is more than 12% of maximum marks, it will be referred to 2-Tier evaluation.
- (v) If the 2-Tier evaluation confirms variation in marks as more than 12% of maximum marks, the variation is considered as follows:
 - a) If the candidate has already passed and obtains more than 12% of the maximum marks on Re-verification, then the variation is considered.
 - b) If the candidate is failed and obtains more than 12% of the maximum marks on Re-verification and secured pass marks on re-verification, then the status of the candidate changes to PASS.
 - c) If a candidate is failed and obtains more than 12% of the maximum marks on Re-verification and if the marks secured on re-verification are still less than the minimum pass marks, the status of the candidate remain FAIL only.

- (vii) After Re-verification of valued answer script the same or change if any therein on Re-verification, will be communicated to the candidate.
- (viii) On Re-verification of Valued Answer Script if the candidate's marks are revised, the fee paid by the candidate will be refunded or else the candidate has to forfeit the fee amount.

Note: No request for Photo copies/ Recounting /Re-verification of valued answer script would be entertained from a candidate who is reported to have resorted to Malpractice in that examination.

20. MAL PRACTICE CASES:

If any candidate resorts to Mal Practice during examinations, he / she shall be booked and the Punishment shall be awarded as per SBTETAP rules and regulations in vogue.

21. DISCREPANCIES/ PLEAS:

Any Discrepancy /Pleas regarding results etc., shall be represented to the SBTETAP within one month from the date of issue of results. Thereafter, no such cases shall be entertained in any manner.

22. ISSUE OF DUPLICATE DIPLOMA

If a candidate loses his/her original Diploma Certificate and desires a duplicate to be issued he/she should produce written evidence to this effect. He / she may obtain a duplicate from the Secretary, State Board of Technical Education and Training, A.P., on payment of prescribed fee and on production of an affidavit signed before a First Class Magistrate (Judicial) and non-traceable certificate from the Department of Police. In case of damage of original Diploma Certificate, he / she may obtain a duplicate certificate by surrendering the original damaged certificate on payment of prescribed fee to the State Board of Technical Education and Training, A.P.

In case the candidate cannot collect the original Diploma within 1 year from the date of issue of the certificate, the candidate has to pay the penalty prescribed by the SBTET AP from time to time.

23. ISSUE OF MIGRATION CERTIFICATE AND TRANSCRIPTS:

The Board on payment of prescribed fee will issue these certificates for the candidates who intend to prosecute Higher Studies in India or Abroad.

24. The following specific changes are discussed and incorporated:

All the courses in earlier curricula are reviewed and the following specific changes are discussed and incorporated.

- i) The topic of "Advanced Surveying using GIS & GPS" was introduced in "Surveying-II (C-304)" at III semester level.
- ii) In "Surveying-II practice & plotting (C-308)", a survey camp of 6-days duration is introduced to acquaint the student with the use and integration of skills already

acquired by him with different surveying instruments. This survey camp is made mandatory for formative assessment.

- iii) The need for having a topic on “Planning & Orientation of Buildings” is felt & suggested by industry people in the Visakhapatnam workshop. As such it is incorporated as one of the topics in the course “Construction Practice (C-306)”
- iv) The course Quantity Surveying in C-16 curriculum is now divided into two courses, as “Quantity Surveying-I (C-403)” & “Quantity Surveying-II (C-503)” to accommodate more exercises on various topics.
- v) A new laboratory course “Surveying-III Practice (C-409)” is introduced at IV semester level with topics on Field exercises in Total Station, GPS & digitization of Maps. A two days camp of 14 hours duration is made mandatory under this course for formative assessment.
- vi) The topics on ‘Tests on Concrete’, ‘Tests on Soils’ are shifted from ‘Material Testing Lab’ and included in the newly introduced course, “Concrete & Soil Testing Practice (C-509)”. Tests on aggregates appropriate to Highway construction and NDT on Concrete are also included in the new course.
- vii) Two new courses, viz., “Construction failures, repairs & maintenance (C-504)”, “Quality Control & Safety in Construction (C-505)” are introduced at V semester, keeping in view the increasing need of supervisory functioning.
- viii) The course “Project Management for Construction” in C-16 curriculum is appropriately renamed as “Construction Management & Entrepreneurship (C-506)”, and hence the topic ‘Concrete Technology’ is shifted to the course on “Construction Materials (C-305)”.
- ix) In “CAD Practice-II (C-510)”, structural engineering drawings are included in addition to the existing drawings of irrigation, public health, culverts & bridges.
- x) The question paper pattern for summative assessment for drawing Subjects except for ‘Engineering Drawing’ in I year is changed as mentioned in the blue print given for each drawing subject.
- xi) The pattern of formative and summative assessment for “Industrial Training (C-601)” is modified, assessing all the skills and competencies needed and acquired by the student during his training in industry.

25. GENERAL

- i. The Board may change or amend the academic rules and regulations or syllabi at any time and the changes or amendments made shall be applicable to all the students, for whom it is intended, with effect from the dates notified by the competent authority.
- ii. All legal matters pertaining to the State Board of Technical Education and Training, AP are within the jurisdiction of Vijayawada.
- iii. In case of any ambiguity in the interpretation of the above rules, the decision of the Secretary, SBTET, A.P is final.

C-20 Curriculum for DCE
With Industrial training(In-house) in Semester VI

VISION

Develop Civil Engineering professionals competent to face the global challenges in a progressive environment conducive to learn technical knowledge, skills blended with ethics and values, to serve the society and to better it for a happy and comfortable living.

MISSION

M1	To provide a competitive learning environment, through a need based curriculum designed in collaboration with industry, conducive for high quality education emphasising on transfer of knowledge and skill development essential for the profession and the society as well.
M2	To nurture higher order leadership qualities and ethics and values in students to enable them to be leaders in their chosen professions while maintaining the highest level of ethics.
M3	To encourage the spirit of inquisition to promote innovation and entrepreneurship strengthened with life skills to sustain the stress.
M4	To foster effective interactions and networking with all the stake holders so as to work towards the growth and sustainability of the society and environment.

PROGRAMME OUTCOMES(POs)

1. **Basic and discipline specific knowledge:** Apply knowledge of basic mathematics, science and engineering fundamentals and engineering specialization to solve the engineering problems.
2. **Problem analysis:** Identify and analyse well-defined engineering problems using codified standard methods.
3. **Design/Development of solutions:** Design solutions for well-defined technical problems and assist with the design of systems components or processes to meet specified needs .
4. **Engineering tools, Experimentation and Testing:** Apply modern engineering tools and appropriate technique to conduct standard tests and measurements.
5. **Engineering practices for society, sustainability and environment:** Apply appropriate technology in context of society, sustainability, environment and ethical practices.
6. **Project Management:** Use engineering management principles individually, as a team member or a leader to manage projects and effectively communicate about well defined engineering activities.

7. **Life-long learning:** Ability to analyse individual needs and engaging updating in the context of technological changes.

PROGRAMME SPECIFIC OUTCOMES (PSOs)

1. An ability to apply disciplines - specific knowledge to solve core and/or applied Civil Engineering problems.
2. An ability to plan and perform experiments and practices and to use the results to solve Civil Engineering problems.
3. Apply appropriate technologies and tools with an understanding of the limitations.

FIRST YEAR

DIPLOMA IN CIVIL ENGINEERING
SCHEME OF INSTRUCTION AND MODEL BLUE PRINT FOR EVALUATION
CURRICULUM-2020
FIRST YEAR

Sub Code	Name of the Subject	Instruction Periods/Week		Total Periods Per Year	Scheme Of Examination			
		Theory	Practical		Duration (hrs)	Sessional Marks	End Exam Marks	Total Marks
THEORY								
C-101	English	3		90	3	20	80	100
C-102	Engineering Mathematics – I	5		150	3	20	80	100
C-103	Engineering Physics	4		120	3	20	80	100
C-104	Engineering Chemistry and Environmental studies	4		120	3	20	80	100
C-105	Engineering Mechanics	5		150	3	20	80	100
C-106	Surveying-I	3		90	3	20	80	100
PRACTICAL								
C-107	Engineering Drawing	-	6	180	3	40	60	100
C-108	Surveying - I Practice & Plotting	-	4+2	180	3	40	60	100
C-109	CE-109(A) : Physics Laboratory	-	3	45+45	1½	20	30	50
	CE-109(B): Chemistry Laboratory	-			1½	20	30	50
C-110	Computer Fundamentals Practice	-	3	90	3	40	60	100
	Total	24	18	1260		280	720	1000

English

Course Code	Course Title	No. of Periods/Week	Total No. of Periods	Marks for FA	Marks for SA
C-101	English	3	90	20	80

S. No.	Unit Title	No of Periods	COs Mapped
1	English for Employability	8	CO1, CO2, CO3, CO4
2	Living in Harmony	8	CO1, CO2, CO3, CO4
3	Connect with Care	8	CO1, CO2, CO3, CO4
4	Humour for Happiness	8	CO1, CO2, CO3, CO4
5	Never Ever Give Up!	8	CO1, CO2, CO3, CO4
6	Preserve or Perish	9	CO1, CO2, CO3, CO4
7	The Rainbow of Diversity	8	CO1, CO2, CO3, CO4
8	New Challenges- Newer Ideas	8	CO1, CO2, CO3, CO4
9	The End Point First!	8	CO1, CO2, CO3, CO4
10	The Equal Halves	8	CO1, CO2, CO3, CO4
11	Dealing with Disaster	9	CO1, CO2, CO3, CO4
Total Periods		90	

Course Objectives	To improve the skills of English Language use by enriching vocabulary and learning accurate structures for effective communication.
	To comprehend themes for value based living in professional and personal settings.

CO No.	Course Outcomes
CO1	Applies perceptions of themes related to societal responsibility of adolescents towards their surroundings.
CO2	Demonstrates knowledge of form and function of 'grammar items' and use them in both academic and everyday situations.
CO3	Demonstrates effective English communication skills with competence in listening, speaking, reading and writing in academic, professional and everyday contexts.
CO4	Displays positivity and values of harmonious living in personal and professional spheres as reflected through communication.

CO-PO Matrix

Course Code C-101	Course Title: English Number of Course Outcomes: 4			No. of Periods: 90	
POs	Mapped with CO No.	CO Periods Addressing PO in Column 1		Level of Mapping (1,2,3)	Remarks
		Number	Percentage		
PO1		Not directly Applicable for English course, however activities that use content from science and technology relevant to the Programme taken up by the student shall be exploited for communication in the Course.			
PO2					
PO3					
PO4					
PO5	CO1, CO2, CO3, CO4	20	22		>50%: Level 3
PO6	CO1, CO2, CO3, CO4	52	58		21-50%: Level 2
PO7	CO1, CO2, CO3, CO4	18	20		Up to 20%: Level 1

Level 3 – Strongly Mapped

Level 2- Moderately Mapped

Level 1- Slightly Mapped

	PO 1	PO 2	PO 3	PO 4	PO 5	PO 6	PO 7
CO 1					✓	✓	✓
CO 2					✓	✓	✓
CO3					✓	✓	✓
CO 4					✓	✓	✓

NOTE: CO-PO groups shall be fulfilled through activities that use content from science and technology relevant to the Programme taken up by the student shall be exploited for communication in the Course.

PO5: Appropriate quiz programme may be conducted at intervals and duration as decided by concerned teacher.

PO6: Seminars on applications of mathematics in various engineering disciplines are to be planned and conducted.

PO7: Such activities are to be planned that students visit library to refer standard books on Mathematics and latest updates in reputed national and international journals, attending seminars, learning mathematical software tools.

Blue Print of Question Paper:

S. No.	Name of the Unit	Periods Allocated	Weightage Allocated	Marks Wise Distribution of Weightage				Question Wise Distribution of Weightage				CO's Mapped			
				R	U	Ap	An	R	U	Ap	An				
1	English for Employability	8	17	3	8*			1	1*	1*		CO1, CO2, CO3, CO4			
2	Living in Harmony	8		3				1					CO1, CO2, CO3, CO4		
3	Connect with Care	8				3							CO1, CO2, CO3, CO4		
4	Humour for Happiness	8	14		3	8*		1	1*			CO1, CO2, CO3, CO4			
5	Never Ever Give Up!	8			3			1			CO1, CO2, CO3, CO4				
6	Preserve or Perish	9	14		8*	3		1*	1			CO1, CO2, CO3, CO4			
7	The Rainbow of Diversity	8				3					1	CO1, CO2, CO3, CO4			
8	New Challenges - Newer Ideas	8	35		8*	8*+ 3+3+ 3	10*	1*	4	1*		CO1, CO2, CO3, CO4			
9	The End Point First!	8													CO1, CO2, CO3, CO4
10	The Equal Halves	8													CO1, CO2, CO3, CO4
11	Dealing with Disasters	9													CO1, CO2, CO3, CO4
TOTAL		90	80	6	30	34	10	2	5	8	1				

PART-A: 10 Questions 3 marks each =30 Marks
 PART-B: 5 Questions 8 marks each =40 Marks
 Part-C: 1 Question 10 marks =10 Marks
 (Higher Order Question)

All Questions are compulsory : 60 minutes
 Internal choice : 90 minutes
 No choice, one compulsory question : 30 minutes

NOTE: * indicates questions can be given from any of the corresponding lessons in the blue print.

Question Paper Pattern for Unit Tests

Part A: 16 marks: 4 questions with 1 mark each (FIB, True/false, one word/phrase, etc.)

4 questions with 3 marks each (short answer/ descriptive/ applicative questions)

Part B: 24 marks: 3 questions 8 marks each with internal choice

Learning Outcomes

1. English for Employability

- 1.1. Explain the need for improving communication in English for employability
- 1.2. Use adjectives and articles effectively while speaking and in writing
- 1.3. Write simple sentences

2. Living in Harmony

- 2.1. Develop positive self-esteem for harmonious relationships
- 2.2. Use affixation to form new words
- 2.3. Use prepositions and use a few phrasal verbs contextually

3. Connect with Care

- 3.1. Use social media with discretion
- 3.2. Speak about abilities and possibilities
- 3.3. Make requests and express obligations
- 3.4. Use modal verbs and main verbs in appropriate form
- 3.5. Write short dialogues for everyday situations

4. Humour for Happiness

- 4.1. Explain the importance of humour for a healthy living
- 4.2. Improve vocabulary related to the theme
- 4.3. Display reading and speaking skills
- 4.4. Frame sentences with proper Subject – Verb agreement
- 4.5. Explain the features of a good paragraph and learn how to gather ideas as a preliminary step for writing a good paragraph.

5. Never Ever Give Up!

- 5.1. Practice to deal with failures in life.
- 5.2. Use the present tense form for various every day communicative functions such as speaking and writing about routines, professions, scientific descriptions and sports commentary.
- 5.3. Write paragraphs with coherence and other necessary skills.

6. Preserve or Perish

- 6.1. Describe the ecological challenges that we face today and act to save the environment.
- 6.2. Narrate / Report past events.
- 6.3. Develop vocabulary related to environment.
- 6.4. Write e-mails.

7. The Rainbow of Diversity

- 7.1. Illustrate and value other cultures for a happy living in multi-cultural workspace
- 7.2. use different types of sentences

- 7.3. Ask for or give directions, information, instructions
- 7.4. Use language to express emotions in various situations
- 7.5. Write letters in various real life situations

8. New Challenges – Newer Ideas

- 8.1. Explain the functional difference between Active Voice and Passive Voice
- 8.2. Use Passive Voice to speak and write in various contexts
- 8.3. List the major parts and salient features of an essay
- 8.4. Explain latest innovations and get motivated

9. The End Point First!

- 9.1. Illustrate the importance of setting a goal in life
- 9.2. Report about what others have said both in speaking and writing
- 9.3. Write an essay following the structure in a cohesive and comprehensive manner
- 9.4. Apply the words related to Goal Setting in conversations and in life

10. The Equal Halves

- 10.1. Value the other genders and develop a gender-balanced view towards life
- 10.2. Identify the use of different conjunctions in synthesising sentences
- 10.3. Write various types of sentences to compare and contrast the ideas
- 10.4. Apply the knowledge of sentence synthesis in revising and rewriting short essays
- 10.5. Develop discourses in speech and writing

11. Dealing with Disasters

- 11.1. Speak and write about different kinds of disasters and the concept of disaster management
- 11.2. Generate vocabulary relevant to disaster management and use it in sentences
- 11.3. Analyze an error in a sentence and correct it
- 11.4. write different kinds of reports

Textbook: INTERACT (A Textbook for I Year English) - Published by SBTET, AP

Reference Books:

- | | |
|---|---|
| Martin Hewings | : Advanced Grammar in Use, Cambridge University Press |
| Murphy, Raymond | : English Grammar in Use, Cambridge University Press |
| Sidney Greenbaum | : Oxford English Grammar, Oxford University Press |
| Wren and Martin (Revised
by N.D.V. Prasad Rao) | : English Grammar and Composition, Blackie ELT Books, S.
Chand and Co. |
| Sarah Freeman | : Strengthen Your Writing, Macmillan |

STATE BOARD OF TECHNICAL EDUCATION –A.P
C20- C-101-ENGLISH
UNIT TEST-1

Time: 90 minutes

Max. Marks: 40

PART-A

4X4= 16 marks

Instructions: Answer all the questions. Each question carries FOUR Marks.

1. Rewrite / Fill in the blank as directed. Each question carries ½ Mark. **(CO2)**
 - a) Write the antonym of 'cruel'
 - b) Write the synonym of 'love'
 - c) Give prefix to 'adventure'.
 - d) Give suffix to 'liberate'
 - e) It is _____ universal truth. (Fill in with suitable article)
 - f) The boy is fond _____ ice-cream. (Fill in the blank with proper preposition)
 - g) He _____ not like sweets. (Fill in the blank with correct primary auxiliary verb.)
 - h) We _____ respect our national flag. (Fill in with a proper modal verb)
2. Rewrite the sentences as directed. Each question carries One mark. 4X1=4 Marks **(CO2)**
 - a) No other metal is so useful as iron. (Change into superlative degree)
 - b) Very few students are so clever as Ramesh. (Change into comparative degree)
 - c) Guess the contextual meaning of the italicized word in the following sentence.
"The CBI officer has *interrogated* the bank employees in connection with the scam."
 - d) _____ only sings plays Prasanth not also well but cricket. (Rearrange the jumbled words)
3. Fill in the blanks with proper form of the verb given in brackets. 4X1 = 4 marks **(CO2)**

The IPSGM _____(hold) in our college last month. Nearly all the colleges in our zone _____(participate) in the event. The prizes _____ (distribute) by the district collector.
Next year, Government Polytechnic, Vijayawada _____ (conduct) the games meet.
4. Rewrite the following sentences after making necessary corrections: 4X 1= 4 Marks **(CO3)**
 - a) The police has arrested the culprit.
 - b) Three hundred miles are a long distance.
 - c) The Principal along with the Heads of Sections have visited the laboratories.
 - d) Either he or I is to blame.

PART-B

3X8=24 Marks

Instructions: Answer all the questions and each question carries EIGHT marks.

5. Write a dialogue of at least five turns between a shopkeeper and customer about buying a mobile phone. **(CO3)**
6. Make an analysis and write a paragraph in around 100 words about your strengths and weaknesses in learning and using English and also the measures to improve it. **(CO3)**
7. Write a paragraph in about 100 words on how to overcome low esteem and negativity.

(CO3, CO4)

STATE BOARD OF TECHNICAL EDUCATION –A.P
C20-C-101-ENGLISH
UNIT TEST-II

Time: 90 minutes

Max. Marks: 40

PART-A

4X4= 16 Marks

Instructions: Answer all the questions. Each question carries FOUR marks.

1. Match the words in column A with their corresponding meanings in column B **(CO2)**

Column A

Column B

- | | |
|--------------|---------------|
| a) Deserve | i) continuous |
| b) hidden | ii) protect |
| c) Preserve | iii) worthy |
| d) Incessant | iv) praise |
| | v) unseen |
| | vi) affection |

2. Rewrite as directed: **(CO3)**

- a) You ask your Mom to give you another chocolate. (Change into a request)
- b) The baby fell down and got injured. (Change into an exclamatory sentence)
- c) The match was very interesting. (Frame a question using 'how')
- d) Hemanth submitted his project report last week. (Frame Yes-No question)

3. Fill in the blanks with appropriate forms of verbs given in brackets: **(CO2)**

- a) The Sun _____ (set) in the west.
- b) Balu _____ (sing) for over fifty years in the films.
- c) We _____ (see) a camel on the road yesterday.
- d) They _____(enter) the stadium before the gates were closed.

4. Change the voice of the following: **(CO2)**

- a) Marconi invented the radio.
- b) Sravanthi has been offered a job.
- c) Pragathi can type the letter.
- d) The Chief Guest will be received by the Final year students.

PART-B

3X8=24 Marks

Answer all the questions. Each question carries EIGHT marks.

5. Write a letter to your younger brother motivating him to deal with failures and hurdles in life. **(CO3)**

6. Write an essay in around 120 words on the role of robots in the modern world. **(CO3)**

7. Read the following passage and answer the questions that follow: **(CO3)**

The greatest enemy of mankind, as people have discovered, is not science, but war. Science merely reflects the social forces by which it is surrounded. It was found that when there is peace, science is constructive when there is war, science is perverted to destructive end. The weapons which science gives us do not necessarily create war. These make war increasingly more terrible. Until now, it has brought us on the doorstep of doom. Our main problem, therefore, is not to curb science, but to substitute law for force, and international government for anarchy in the relations of one nation with another. That is a job in which everybody must participate, including the scientists.

Now we are face to face with these urgent questions: Can education and tolerance, understanding and creative intelligence run fast enough to keep us side by side without our mounting capacity to destroy? That is the question which we shall have to answer, one way or the other, in this generation. Science must help us in the answer, but the main decision lies within ourselves. The hour is late and our work has scarcely begun.

- a. What is the chief enemy of man?
- b. What does science reflect?
- c. When is science perverted?
- d. What makes war more terrible?
- e. Why do we need international government?
- f. What are the four aspects that may stop destruction?
- g. Have we really started our work to fight the problem discussed?
- h. Pick the word from the passage that would mean: 'replace with other one'

STATE BOARD OF TECHNICAL EDUCATION –A.P
C20-C-101-ENGLISH
UNIT TEST-III

Time: 90 minutes

Max. Marks: 40

PART-A

4X4 = 16 Marks

Instructions: Answer all the questions. Each question carries Four marks.

1. Give the meaning of the word in italics: **(CO3)**
 - a) When the girls laughed in the class, the teacher was *furious*.
 - b) He was *rusticated* from the school for his misbehavior.
 - c) Vikramaditya was a *benevolent* Indian King.
 - d) We should not show any *discrimination* between boys and girls.
2. Change the speech of the following: **(CO2)**
 - a) He said, "I am sorry."
 - b) The teacher said to the boys, "Why are you late?"
 - c) Sushma said that she had submitted her report recently.
 - d) Pratap requested Priya to give him her pen.
3. Rewrite as directed: **(CO2)**
 - a) Though he was weak, he took the test. (change into a simple sentence)
 - b) You must work hard to achieve success. (change into a complex sentence)
 - c) If you run fast, you will catch the bus. (change into a compound sentence)
 - d) The fog disappeared when the Sun rose. (Split into two simple sentences)
4. Locate eight errors from the following passage and correct them. **(CO2)**

Once upon a time there live a king who was very kind to his people. In his council of ministers, there is a wise man. He had a son called Sumanth who was a educated and highly learned. Once the wise minister fall sick. All the physicists in the country could not heal him. Then Sumanth will go in search of medicine in Himalayas. He bring the special medicinal roots to cure his father's sickness. Sumanth looked before his father carefully and healed him. The king rewarded Sumanth with rich gifts.

PART- B

3X8 = 24 Marks

Instructions: Answer all the questions and each one carries eight marks.

5. Read the following paragraph and make notes first and then its summary. **(CO3)**

Astronauts are people who travel on space ships. They need to have a very clean home. They travel far from Earth. We need clean kitchens everywhere on earth and in space. Astronauts have to solve two problems: how to get food and how to keep their spaceship clean. Here is how they solved the food problem. At first, the astronauts took tubes of food with them into space. They would squeeze a tube and eat semi-liquid food. It did not taste great, but since they did not need to take dishes or silverware with them, they had no dishes to wash. Today's spaceships have a bigger menu. Astronauts can eat from bowls. In fact, they take cereal and other standard foods with them. The foods are packaged in special containers to keep them fresh. They use knives, forks, and spoons. One unusual item on their table is a pair of scissors. They use the scissors to open the food packages. They can eat right from the package. They have a kitchen on

the spaceship. Its oven can heat food to 170 degrees. The kitchen has water and sets of meals that come on trays. The astronauts choose their menu before they go into space. They take a lot of food with them. The astronauts keep bread and fresh fruits and vegetables in a special food locker. How do they keep the kitchen clean? They do not have to worry about mice or other rodents. They make sure that there are no rodents before the ship leaves. But sometimes mice travel on the ship. Those mice are part of experiments. They live in cages. How do astronauts keep their trays clean? That is another health problem the astronauts solve. They need to stay healthy in space. To carry a lot of water to wash trays would be a lot of extra weight. They pack wet wipes in plastic bags. They use them to clean trays. So, their kitchen is clean and they stay healthy.

6. Write an essay in about 120 words on the importance of goal setting and your short and long term goals. **(CO3,CO4)**
7. Write a report about the bush fire that raged in Australia recently by using the following clues: forest, natural disaster, wild fire, dried leaves, no rain fall, wild animals, burnt alive, loss of flora and fauna, fire fighters, uncontrollable, moderate rains, environmental pollution, measures to protect...etc. **(CO3)**

STATE BOARD OF TECHNICAL EDUCATION- A.P
Model Question Paper
C20-C-101- ENGLISH

Time: 3hrs

Max.Marks:80

PART-A

10X3=30 Marks

Instructions: Answer all the questions. Each question carries Three marks.

1. a) Fill in the blanks with suitable articles: **(CO2)**
I have seen _____ European at _____ local market.
- b) Fill in with proper form of adjective given in the bracket: **(CO2)**
China is the _____ country in the world. (populous, more populous, most populous)
- c) i) Choose the synonym from the following for the word : 'filthy' **(CO3)**
dirty / clean / hygienic / tidy
- ii) Choose the antonym from the following for the word: 'exterior' **(CO3)**
external / internal / open / interior
2. a) i) Give prefix for the word: 'popular' **(CO2)**
ii) Write suffix for the word : 'king' **(CO2)**
- b) He was married _____ her _____ January 2015. (Fill in with appropriate preposition) **(CO3)**
- c) Match the words in column A with their corresponding meanings in column B: **(CO2)**
- | Column-A | Column-B |
|-----------------|-----------------|
| i) Dynamic | a) tasty |
| ii) Gloomy | b) active |
| | c) sad |
| | d) proud |
3. a) The old man *hunted* for his spectacles. (Give the contextual meaning of the word in italics) **(CO3)**
- b) The committee / have submitted / its report / to the President. (identify the part which contains an error) **(CO3)**
- c) recently has a scooter purchased Shanthy. (Rearrange the jumbled words to make a meaningful sentence.) **(CO3)**
4. a) Use the following primary auxiliary verb in sentence of your own: **(CO2)**
' does'
- b) Fill in the blank with proper modal auxiliary verb based on the clue in the bracket: **(CO2)**
Harish _____ speak four languages. (ability)
- c) Rakesh wants two hundred rupees from his father. (Write the sentence how he requests his Father) **(CO2)**

5. Fill in the blanks with suitable form of the verb given in brackets: **(CO2)**

- a) He _____ (go) for a walk daily.
- b) The bus _____ (arrive) just now.
- c) We _____ (live) in Chennai since 2005.

6. Change the voice of the following sentences: **(CO2)**

- a) English is spoken all over the world.
- b) They watched a movie yesterday.
- c) The Chief Minister will inaugurate the exhibition.

7. a) It is a beautiful rainbow. (Change into an exclamatory sentence) **(CO3)**

b) C.V. Raman won the Nobel Prize in 1930. (Frame a question using 'When') **(CO3)**

c) He can swim across the river. (change into 'Yes / No' question) **(CO3)**

8. Change the speech of the following: **(CO2)**

- a) He said, "I will go to Delhi tomorrow."
- b) Ravi said to Ashok, " Where are you going?"
- c) She told him to mind his own business.

9. Rewrite as directed: **(CO2)**

- a) In spite of being busy he attended the meeting. (Rewrite the sentence using 'though')
- b) She is poor. She is honest. (combine the two sentences using 'but')
- c) On seeing the tiger, he climbed a tree. (split into two simple sentences)

10. Rewrite the following sentences after making necessary corrections: **(CO2)**

- a) We have gone to picnic yesterday.
- b) Suresh watched T.V when I went to his house.
- c) They left Gujarat before the earthquake occurred.

PART-B

5X8=40

Instructions: Answer the following questions. Each question carries EIGHT marks.

11. Write a paragraph in about 100 words on what you do daily. **(CO3,CO4)**

OR

Write a paragraph in about 100 words on the uses and misuses of social media.

12. Construct a dialogue of at least five turns between an American and you about places worth visiting in your city. **(CO3,CO4)**

OR

Compose a dialogue of at least five turns between two friends, one favouring homemade food and the other, fast foods.

13. Write a letter to your parents about your preparation for year-end examinations. **(CO3,CO4)**

OR

Write a letter to the editor of a newspaper about the inconvenience caused due to loud speakers in your area.

14. Write an essay in about 120 words on measures to prevent water pollution.

OR

Write an essay in about 120 words on importance of gender equality.

15. Read the following passage and answer the questions that follow: **(CO3)**

A farmer in ancient China had a neighbour who was a hunter, and who owned ferocious and poorly trained hunting dogs. They jumped over the fence frequently and chased the farmer's lambs. The farmer asked his neighbour to keep his dogs in check, but this fell on deaf ears. One day the dogs again jumped the fence, attacked and severely injured several of the lambs.

The farmer had had enough, and went to town to consult a judge who listened carefully to the story and said: "I could punish the hunter and instruct him to keep his dogs chained or lock them up. But you would lose a friend and gain an enemy. Which would you rather have, friend or foe for a neighbour?" The farmer replied that he preferred a friend. "Alright, I will offer you a solution that keeps your lambs safe, and which will keep your a neighbour a friend." Having heard the judge's solution, the farmer agreed.

Once at home, the farmer immediately put the judge's suggestions to the test. He took three of his best lambs and presented them to his neighbour's three small sons, who were beside themselves with joy and began to play with them. To protect his son's newly acquired playthings, the hunter built a strong kennel for his dogs. Since then, the dogs never again bothered the farmer's lambs. Out of gratitude for the farmer's generosity toward his sons, the hunter often shared the game he had hunted with the farmer. The farmer reciprocated by sending the hunter the cheese he had made. Within a short time the neighbours became good friends.

- a) What kind of dogs does the neighbor have?
- b) When did the farmer consult the judge?
- c) What would be the consequence if the judge punished the neighbor?
- d) What was the solution suggested by the judge?
- e) What did the neighbour's sons do with the gifts they received?
- f) How did the dogs stop bothering the farmer's lambs?
- g) What items are exchanged happily between the two neighbours?
- h) Pick the word from the passage that would mean: 'a closed shelter for dogs'.

OR

Read the following short poem and answer the questions that follow:

Crisp in the winter's morning,

Softly all through the night,

What is this without warning,

Falling and white?

I have never seen snow,

But I can imagine it quite –
Not how it tastes, but I know,
It falls and is white.

One morning I'll open the door,
To bring in the morning's milk,
And all around there'll be snow –
Fallen and still.

How I'll roll in the stuff!
How I'll tumble and spin!
Until the neighbours cry,
Enough! And send me back in.

Q.1. What is the poem about?

2. How does snow fall?

3. Did you ever touch snow? How did you feel?

4. a) Pick the word from the poem that means 'slip and fall'

b) Write the antonym for the word 'soft'

SECTION – C

1X10=10 Marks

16. Write a report on the blood donation camp organized by International Red Cross Society in your college. Use the following clues: date, time, place, arrangements, donors, equipment, doctors, response, sponsors, snacks, volunteers, help others, save lives...etc.

Course Code	Course Title	No. of Periods/week	Total No. of periods	Marks for FA	Marks for SA
C-102	Engineering Mathematics-I	5	150	20	80

S.No.	Unit Title	No. of periods	COs mapped
1	Algebra	31	CO1
2	Trigonometry	44	CO2
3	Co-ordinate Geometry	23	CO3
4	Differential Calculus	33	CO4
5	Applications of Differentiation	19	CO4, CO5
Total Periods		150	

Course Objectives	<p>(i) To apply the principles of Algebra, Trigonometry and Co-Ordinate Geometry to real-time problems in engineering.</p> <p>(ii) To comprehend and apply the concept of Differential Calculus in engineering applications.</p>
--------------------------	--

Course Outcomes	CO1	Identify various functions, resolve partial fractions and solve problems on matrices.
	CO2	Solve problems using the concept of trigonometric functions, their inverses and complex numbers.
	CO3	Find the equations and properties of straight lines, circles and conic sections in coordinate system.
	CO4	Evaluate the limits and derivatives of various functions.
	CO5	Evaluate solutions for engineering problems using differentiation.

**ENGINEERING MATHEMATICS – I
COMMON TO ALL BRANCHES**

Learning Outcomes

UNIT - I

C.O. 1 Identify various functions, resolve partial fractions and solve problems on matrices.

L.O. 1.1 Define Set, ordered pairs and Cartesian product - examples.

1.2 Explain Relations and functions – examples

1.3 Find Domain & Range of functions – simple examples.

1.4 Classify types of functions (into, many-to-one, one-one, onto and bijective).

1.5 Define inverse functions - examples.

1.6 Define rational, proper and improper fractions of polynomials.

1.7 Explain the procedure of resolving rational fractions of the type mentioned below into partial fractions

$$i) \frac{f(x)}{(ax+b)(cx+d)} \quad ii) \frac{f(x)}{(ax+b)^2(cx+d)}$$

$$iii) \frac{f(x)}{(x^2+a^2)(bx+c)} \quad iv) \frac{f(x)}{(x^2+a^2)(x^2+b^2)}$$

- 1.8 Define a matrix and order of a matrix.
- 1.9 State various types of matrices with examples (emphasis on 3rd order square matrices).
- 1.10 Compute sum, scalar multiplication and product of matrices. Illustrate the properties of these operations such as associative, distributive, commutative properties with examples and counter examples.
- 1.11 Define the transpose of a matrix and write its properties;
- 1.12 Define symmetric and skew-symmetric matrices with examples. Resolve a square matrix into a sum of a symmetric and skew-symmetric matrices and provide examples.
- 1.13 Define determinant of a square matrix, minor, co-factor of an element of a 3x3 square matrix with examples. Expand the determinant of a 3 x 3 matrix using Laplace expansion formula. State and apply the properties of determinants to solve problems.
- 1.14 Distinguish singular and non-singular matrices. Define multiplicative inverse of a matrix and list properties of adjoint and inverse. Compute adjoint and multiplicative inverse of a square matrix.
- 1.15 Solve system of 3 linear equations in 3 unknowns using Cramer's rule and matrix inversion method.

UNIT - II

C.O.2 Solve problems using the concept of trigonometric functions, their inverses and complex numbers.

- L.O.** 2.1 Define trigonometric ratios of any angle.
- 2.2 List the values of trigonometric ratios at specified values.
- 2.3 Draw graphs of trigonometric functions.
- 2.4 Explain periodicity of trigonometric functions.
- 2.5 Define compound angles and state the formulae of $\sin(A \pm B)$, $\cos(A \pm B)$, $\tan(A \pm B)$ and $\cot(A \pm B)$.
- 2.6 Give simple examples on compound angles to derive the values of $\sin 15^\circ$, $\cos 15^\circ$, $\sin 75^\circ$, $\cos 75^\circ$, $\tan 15^\circ$, $\tan 75^\circ$ etc.
- 2.7 Derive identities like $\sin(A+B) \sin(A-B) = \sin^2 A - \sin^2 B$ etc.
- 2.8 Solve simple problems on compound angles.
- 2.9 Derive the formulae of multiple angles $2A$, $3A$ etc and sub multiple angles $A/2$ in terms of angle A of trigonometric functions.
- 2.10 Derive useful allied formulas like $\sin^2 A = (1 - \cos 2A)/2$ etc.
- 2.11 Solve simple problems using the above formulae

Syllabus for Unit test-I completed

- 2.12 Derive the formulae on transforming sum or difference of two trigonometric ratios into a product and vice versa, examples on these formulae.
- 2.13 Solve problems by applying these formulae to sum or difference or product of three or more terms.

- 2.14 Explain the concept of the inverse of a trigonometric function by selecting an appropriate domain and range.
- 2.15 Define inverses of six trigonometric functions along with their domains and ranges.
- 2.16 Derive relations between inverse trigonometric functions so that given $A = \sin^{-1}x$, express angle A in terms of other inverse trigonometric functions with examples.
- 2.17 State various properties of inverse trigonometric functions and identities like $\sin^{-1}x + \cos^{-1}x = \frac{\pi}{2}$ etc.
- 2.18 Apply formulae like $\tan^{-1}x + \tan^{-1}y = \tan^{-1}\left(\frac{x+y}{1-xy}\right)$, where $x \geq 0, y \geq 0, xy < 1$ etc., to solve Simple problems.
- 2.19 Explain what is meant by solutions of trigonometric equations and find the general solutions of $\sin x = k$, $\cos x = k$ and $\tan x = k$ with appropriate examples.
- 2.20 Solve models of the type $a \sin^2 x + b \sin x + c = 0$, $a \cos x + b \sin x = c$ etc., and problems using simple transformations.
- 2.21 State sine rule, cosine rule, tangent rule and projection rule.
- 2.22 Explain the formulae for $\sin A/2$, $\cos A/2$, $\tan A/2$ and $\cot A/2$ in terms of semi-perimeter S and sides a, b, c and solve problems.
- 2.23 List various formulae for the area of a triangle.
- 2.24 Solve problems using the above formulae.
- 2.25 Define Sinh x , cosh x and tanh x and list the hyperbolic identities.
- 2.26 Represent inverse hyperbolic functions in terms of logarithms.
- 2.27 Define complex number, its modulus, conjugate and list their properties.
- 2.28 Define the operations on complex numbers with examples.
- 2.29 Define amplitude of a complex number.
- 2.30 Represent the complex number in various forms like modulus-amplitude (polar) form, Exponential (Euler) form with examples.
- 2.31 Write DeMoivre's theorem (without proof) and illustrate with simple examples.

UNIT - III

Coordinate Geometry

C.O. 3 Find the equations and properties of straight lines, circles and conic sections in coordinate system.

- L.O.** 3.1 Write the different forms of a straight line – general form, point-slope form, slope-intercept form, two-point form, intercept form and normal form or perpendicular form.
- 3.2 Solve simple problems on the above forms.
- 3.3 Find distance of a point from a line, acute angle between two lines, intersection of two non parallel lines and distance between two parallel lines.
- 3.4 Define locus of a point and define a circle.
- 3.5 Write the general equation of a circle and find the centre and radius.
- 3.6 Find the equation of a circle given (i) centre and radius, (ii) two ends of a diameter (iii) Centre and a point on the circumference (iv) three non collinear points.

- 3.7. Define a conic section.
- 3.8 Explain the terms focus, directrix, eccentricity, axes and latus rectum of a conic with illustrations.
- 3.9 Find the equation of a conic when focus, directrix and eccentricity are given.
- 3.10 Describe the properties of Parabola, Ellipse and Hyperbola in standard forms whose axes are along co-ordinate axes and solve simple examples on above.

Syllabus for Unit test-II completed

C.O.4 Evaluate the limits and derivatives of various functions.

L.O. 4.1 Explain the concept of limit and meaning of $\lim_{x \rightarrow a} f(x) = l$ and state the properties of limits.

4.2 Evaluate the limits of the type $\lim_{x \rightarrow a} \frac{f(x)}{g(x)}$ and $\lim_{x \rightarrow \infty} \frac{f(x)}{g(x)}$

4.3 Mention the Standard limits $\lim_{x \rightarrow a} \frac{x^n - a^n}{x - a}$, $\lim_{x \rightarrow 0} \frac{\sin x}{x}$, $\lim_{x \rightarrow 0} \frac{\tan x}{x}$, $\lim_{x \rightarrow 0} \frac{a^x - 1}{x}$,

$\lim_{x \rightarrow 0} \frac{e^x - 1}{x}$, $\lim_{x \rightarrow 0} (1+x)^{\frac{1}{x}}$, $\lim_{x \rightarrow \infty} \left(1 + \frac{1}{x}\right)^x$ (without proof) and solve the problems

using these standard limits.

- 4.4 Explain the concept of continuity of a function at a point and on an interval with some examples whether a given function is continuous or not.
- 4.5 State the concept of derivative of a function $y = f(x)$ – definition, first principle as $\lim_{h \rightarrow 0} \frac{f(x+h) - f(x)}{h}$ and also provide standard notations to denote the derivative of a function.
- 4.6 State the significance of derivative in scientific and engineering applications.
- 4.7 Find the derivatives of elementary functions like x^n , a^x , e^x , $\log x$, $\sin x$, $\cos x$, $\tan x$, $\sec x$, $\csc x$ and $\cot x$ using the first principles.
- 4.8 Find the derivatives of simple functions from the first principle .
- 4.9 State the rules of differentiation of sum, difference, scalar multiplication, product and quotient of functions with illustrative and simple examples.
- 4.10 Explain the method of differentiation of a function of a function (Chain rule) with illustrative examples.
- 4.11 Find the derivatives of Inverse Trigonometric functions and examples using the Trigonometric transformations.
- 4.12 Explain the method of differentiation of a function with respect to another function and also differentiation of parametric functions with examples.
- 4.13 Find the derivatives of hyperbolic functions.
- 4.14 Explain the procedures for finding the derivatives of implicit function with examples.
- 4.15 Explain the need of taking logarithms for differentiating some functions with examples like $[f(x)]^{g(x)}$.
- 4.16 Explain the concept of finding the higher order derivatives of second and third order with examples.

- 4.17 Explain the concept of functions of several variables, partial derivatives and difference between the ordinary and partial derivatives with simple examples.
- 4.18 Explain the definition of Homogenous function of degree n.
- 4.19 Explain Euler's theorem for homogeneous functions with applications to simple problems.

C.O. 5 Evaluate solutions for engineering problems using differentiation.

- L.O.** 5.1 State the geometrical meaning of the derivative as the slope of the tangent to the curve $y=f(x)$ at any point on the curve.
- 5.2 Explain the concept of derivative to find the slope of tangent and to find the equation of tangent and normal to the curve $y=f(x)$ at any point on it.
- 5.3 Find the lengths of tangent, normal, sub-tangent and sub normal at any point on the curve $y=f(x)$.
- 5.4 Explain the derivative as a rate of change in distance-time relations to find the velocity and acceleration of a moving particle with examples.
- 5.5 Explain the derivative as a rate measurer in the problems where the quantities like volumes, areas vary with respect to time- illustrative examples.
- 5.6 Define the concept of increasing and decreasing functions.
- 5.7 Explain the conditions to find points where the given function is increasing or decreasing with illustrative examples.
- 5.8 Explain the procedure to find the extreme values (maxima or minima) of a function of single variable- simple problems yielding maxima and minima.
- 5.9 Solve problems on maxima and minima in applications like finding areas, volumes etc.
- 5.10 Apply the concept of derivatives to find the errors and approximations in simple problems.

Syllabus for Unit test-III completed

CO/PO – Mapping

	PO1	PO2	PO3	PO4	PO5	PO6	PO7	PSO1	PSO2	PSO3
CO1	3	2	1	2				3	2	3
CO2	3	3	3	2				3	3	1
CO3	3	2	2	1				3	2	2
CO4	3	3	2	2				3	2	1
CO5	3	3	3	3				3	3	3
Avg	3	2.6	2.5	2				3	2.4	2

3 = Strongly mapped (High), **2** =moderately mapped (Medium), **1** =slightly mapped (Low)

Note:

PO5: Appropriate quiz programme may be conducted at intervals and duration as decided by concerned teacher.

PO6: Seminars on applications of mathematics in various engineering disciplines are to be planned and conducted.

PO7: Such activities are to be planned that students visit library to refer standard books on Mathematics and latest updates in reputed national and international journals, attending seminars, learning mathematical software tools.

PSO1: An ability to understand the concepts of basic mathematical concepts and to apply them in various areas like computer programming, civil constructions, fluid dynamics, electrical and electronic systems and all concerned engineering disciplines.

PSO2: An ability to solve the Engineering problems using latest software tool, along with analytical skills to arrive at faster and appropriate solutions.

PSO3: Wisdom of social and environmental awareness along with ethical responsibility to have a successful career as an engineer and to sustain passion and zeal for real world technological applications.

PO- CO – Mapping strength

PO no	Mapped with CO no	CO periods addressing PO in column I		Level (1,2 or 3)	Remarks
		No	%		
1	CO1, CO2, CO3,CO4,CO5	150	100%	3	>40% Level 3 Highly addressed 25% to 40% Level 2 Moderately addressed 5% to 25% Level 1 Low addressed <5% Not addressed
2	CO1, CO2, CO3,CO4,CO5	138	92%	3	
3	CO1, CO2, CO3,CO4,CO5	133	88.6%	3	
4	CO1, CO2, CO3,CO4,CO5	120	80%	3	
PSO 1	CO1, CO2, CO3,CO4,CO5	150	100%	3	
PSO 2	CO1, CO2, CO3,CO4,CO5	135	90%	3	
PSO 3	CO1, CO2, CO3,CO4,CO5	125	83.3%	3	

COMMON TO ALL BRANCHES

COURSE CONTENT

Unit-I

Algebra

1. Relations and Functions:

Define Set, Ordered pairs, Cartesian product, Relations, functions, domain & range of functions. Describe types of functions (in-to, many-to-one, one-one, onto and bijective) and inverse functions – examples.

2. Partial Fractions:

Define rational, proper and improper fractions of polynomials. Resolve rational fractions in to their partial fractions covering the types mentioned below.

$$i) \frac{f(x)}{(ax+b)(cx+d)} \quad ii) \frac{f(x)}{(ax+b)^2(cx+d)}$$

$$iii) \frac{f(x)}{(x^2+a^2)(bx+c)} \quad iv) \frac{f(x)}{(x^2+a^2)(x^2+b^2)}$$

3. Matrices:

Definition of a matrix, types of matrices-examples, algebra of matrices-equality of two matrices, sum, scalar multiplication and product of matrices. Transpose of a matrix-Symmetric, skew symmetric matrices-Minor, cofactor of an element-Determinant of a square matrix-Laplace's expansion, properties of determinants. Singular and non-singular matrices-Adjoint and multiplicative inverse of a square matrix- examples-System of linear equations in 3 variables-Solutions by Cramers's rule and Matrix inversion method-examples.

Unit-II

Trigonometry

4. Trigonometric ratios:

Definition of trigonometric ratios of any angle, values of trigonometric ratios at specified values, draw graphs of trigonometric functions, periodicity of trigonometric functions.

5. Compound angles:

Formulas of $\sin(A \pm B)$, $\cos(A \pm B)$, $\tan(A \pm B)$, $\cot(A \pm B)$, and related identities with problems.

6. Multiple and sub multiple angles:

Formulae for trigonometric ratios of multiple angles $2A$, $3A$ and sub multiple angles $A/2$ with problems.

7. Transformations of products into sums or differences and vice versa simple problems

8. Inverse trigonometric functions:

Definition, domains and ranges-basic properties- problems.

9. Trigonometric equations:

Concept of a solution, principal value and general solution of trigonometric equations: $\sin x = k$, $\cos x = k$, $\tan x = k$, where k is a constant. Solutions of simple quadratic equations, equations involving usage of transformations- problems.

10. Properties of triangles:

Relation between sides and angles of a triangle- sine rule, cosine rule, tangent rule and projection rule-area of a triangle- problems.

11. Hyperbolic functions:

Definitions of hyperbolic functions, identities of hyperbolic functions, inverse hyperbolic functions and expression of inverse hyperbolic functions in terms of logarithms.

12. Complex Numbers:

Definition of a complex number, Modulus and conjugate of a complex number, Arithmetic operations on complex numbers, Modulus- Amplitude (polar) form, Exponential form (Euler form) of a complex number- Problems. DeMoivre's theorem.

UNIT-III

Coordinate geometry

- 13 Straight lines:** various forms of straight lines, angle between lines, perpendicular distance from a point, distance between parallel lines-examples.
- 14. Circle:** locus of a point, Circle, definition-Circle equation given (i) centre and radius, (ii) two ends of a diameter (iii) centre and a point on the circumference (iv) three non collinear points - general equation of a circle – finding centre, radius.
- 15.** Definition of a conic section, equation of a conic when focus directrix and eccentricity are given. properties of parabola, ellipse and hyperbola in standard forms.

UNIT-IV

Differential Calculus:

16. Concept of Limit- Definition- Properties of Limits and Standard Limits -Simple Problems- Continuity of a function at a point- Simple Examples only.

17. Concept of derivative- Definition (first principle)- different notations-derivatives of elementary functions- problems. Derivatives of sum, product, quotient, scalar multiplication of functions - problems. Chain rule, derivatives of inverse trigonometric functions, derivative of a function with respect to another function, derivative of parametric functions, derivative of hyperbolic, implicit functions, logarithmic differentiation – problems in each case. Higher order derivatives - examples – functions of several variables - partial differentiation, Euler’s theorem-simple problems.

UNIT-V

Applications of Derivatives:

- 18.** Geometrical meaning of the derivative, equations of Tangent and normal to a curve at any point. Lengths of tangent, normal, sub tangent and subnormal to the curve at any point - problems.
- 19.** Physical applications of the derivative – velocity, acceleration, derivative as a rate measure –Problems.
- 20.** Applications of the derivative to find the extreme values – Increasing and decreasing functions, finding the maxima and minima of simple functions - problems leading to applications of maxima and minima.
- 21.** Using the concept of derivative of a function of single variable, find the absolute error, relative and percentage errors and approximate values due to errors in measuring.

Textbook:

Engineering Mathematics-I, a textbook for first year diploma courses, prepared & prescribed by SBTET, AP.

Reference Books:

1. Shanti Narayan, A Textbook of matrices, S.Chand &Co.
2. Robert E. Moyer & Frank Ayers Jr., Schaum's Outline of Trigonometry, 4th Edition, Schaum's Series
3. M.Vygodsky, Mathematical Handbook, Mir Publishers, Moscow.
4. Frank Ayers & Elliott Mendelson, Schaum's Outline of Calculus, Schaum's Series

**Engineering Mathematics – I
Blue print**

S. No	Chapter/ Unit title	No of Periods		Weightage Allotted	Marks wise distribution of weight age				Question wise distribution of weight age				COs mapped
		Theory	Practice		R	U	Ap	An	R	U	Ap	An	
	Unit - I : Algebra												
1	Relations and Functions	4	2	3	0	3	0	0	0	1	0	0	CO 1
2	Partial Fractions	3	2	3	0	3	0	0	0	1	0	0	CO 1
3	Matrices and Determinants	10	10	11	3	0	8	0	1	0	1	0	CO 1
	Unit - II : Trigonometry												
4	Trigonometric Ratios	1	1	0	0	0	0	0	0	0	0	0	CO2
5	Compound Angles	3	2	3	3	0	0	0	1	0	0	0	CO2
6	Multiple and Submultiple angles	4	4	3	0	3	0	0	0	1	0	0	CO2
7	Transformations	3	3	8	0	8	0	0	0	1	0	0	CO2
8	Inverse Trigonometric Functions	3	2										
9	Trigonometric Equations	3	2										
10	Properties of triangles	3	2										
11	Hyperbolic Functions	1	1	0	0	0	0	0	0	0	0	0	CO2
12	Complex Numbers	4	2	3	3	0	0	0	1	0	0	0	CO2

Unit III : Co-ordinate Geometry													
13	Straight Lines	4	2	3	3	0	0	0	1	0	0	0	CO3
14	Circle	3	2	8	0	8	0	0	0	1	0	0	CO3
15	Conic Sections	8	4										
Unit – IV : Differential Calculus													
16	Limits and Continuity	4	2	3	0	3	0	0	0	1	0	0	CO4
17	Differentiation	17	10	14	3	11	0	0	1	2	0	0	CO4
Unit - V : Applications of Differentiation													
18	Geometrical Applications	3	2	10	0	0	0	10	0	0	0	1	CO5
19	Physical Applications	2	2										
20	Maxima and Minima	3	4										
21	Errors and Approximations	2	1										
Total		89	61	80	15	39	16	10	5	8	2	1	

R: Remembering Type : 15 Marks
U: understanding Type : 39 Marks
Ap: Application Type : 16 Marks
An: Analysing Type : 10 Marks

Engineering Mathematics – I
Unit Test Syllabus

Unit Test	Syllabus
Unit Test-I	From L.O. 1.1 to L.O. 2.11
Unit Test-II	From L.O. 2.12 to L.O. 3.10
Unit Test-III	From L.O.4.1 to L.O. 5.10

State Board of Technical Education and Training, A. P

First Year

Subject name: **Engineering Mathematics-I**Sub Code: **C-102**

Time : 90 minutes

Max.marks:40

Part-A

16Marks

Instructions: (1) Answer all questions.

(2) First question carries four marks and the remaining questions carry three marks each.

1. Answer the following.

a. If $f(x)=x^2$ and domain $=\{-1,0,1\}$, then find range. (CO1)

b. If $A=\begin{bmatrix} 1 & 2 \\ 3 & 4 \end{bmatrix}$, then find $3A$. (CO1)

c. Write the value of $\sin 120^\circ$ (CO2)

d. Write the formula for $\tan 2A$ in terms of $\tan A$ (CO2)

2. If $f:R \rightarrow R$ is defined by $f(x)=3x-5$, then prove that $f(x)$ is onto. (CO1)

3. If $A=\begin{bmatrix} 1 & 3 \\ 4 & -9 \end{bmatrix}$, $B=\begin{bmatrix} 2 & 4 \\ -3 & 1 \end{bmatrix}$ then find $2A+3B$ (CO1)

4. Prove that $\sin^2 45^\circ - \sin^2 15^\circ = \frac{\sqrt{3}}{4}$ (CO2)

5. Prove that $\frac{\sin 2A}{1-\cos 2A} = \cot A$ (CO2)

Part-B

3×8=24

Instructions: (1) Answer all questions.

(2) Each question carries eight marks

(3) Answer should be comprehensive and the criterion for valuation is the content but not the length of the answer.

6. A) Resolve $\frac{2x}{(x-1)(x-3)}$ into partial fractions. (CO1)

or

B) Resolve $\frac{x+4}{x^2-3x+2}$ into partial fractions. (CO1)

7. A) Using Cramer's rule to solve
 $x-y+z=2, 2x+3y-4z=-4, 3x+y+z=8$ (CO1)

or

B) Prove that $\begin{vmatrix} bc & b+c & 1 \\ ca & c+a & 1 \\ ab & a+b & 1 \end{vmatrix} = (a-b)(b-c)(c-a)$ (CO1)

8. A) Find the adjoint of Matrix $\begin{bmatrix} 1 & 2 & -2 \\ -1 & 3 & 5 \\ 2 & 7 & -4 \end{bmatrix}$ (CO1)

or

B) If $A = \begin{bmatrix} 2 & 3 & 4 \\ 5 & 7 & 9 \\ -2 & 1 & 3 \end{bmatrix}$, $B = \begin{bmatrix} 3 & 1 & -5 \\ 2 & 1 & 4 \\ 0 & 3 & 1 \end{bmatrix}$, find AB and BA and verify if $AB = BA$.

(CO1)

-o0o-

Unit Test II

C –20, C -102

State Board of Technical Education and Training, A. P

First Year

Subject name: Engineering Mathematics-I

Sub Code: C- 102

Time : 90 minutes

Max.marks:40

Part-A

16Marks

Instructions: (1) Answer all questions.

(2) First question carries four marks and the remaining questions carry three marks each

1. Answer the following.

a. $\sin C + \sin D = 2 \cos\left(\frac{C+D}{2}\right) \sin\left(\frac{C-D}{2}\right)$: State TRUE/FALSE (CO2)

b. If $z = 2 + 3i$, then find $|z|$ (CO2)

c. $\sinh x = \frac{e^x - e^{-x}}{2}$: State TRUE/FALSE (CO2)

d. Write the eccentricity of rectangular hyperbola. (CO3)

2. Express $(3-4i)(7+2i)$ in terms of $a+ib$ (CO2)

3. Find the perpendicular distance from $(1,1)$ to the line $2x+3y-1=0$ (CO3)

4. Find the angle between lines $2x-y+3=0$ and $x+y-2=0$ (CO3)

5. Find the centre and radius of the circle $x^2 + y^2 - 2x + 4y - 4 = 0$ (CO3)

Part-B

3×8=24

Instructions: (1) Answer all questions.

(2) Each question carries eight marks

(3) Answer should be comprehensive and the criterion for valuation is the content but not the length of the answer.

6. A) Prove that $\frac{\sin 2\theta + \sin 4\theta + \sin 6\theta}{\cos 2\theta + \cos 4\theta + \cos 6\theta} = \tan 4\theta$. (CO2)

or

B) Prove that $\tan^{-1} \frac{1}{2} + \tan^{-1} \frac{1}{5} + \tan^{-1} \frac{1}{8} = \frac{\pi}{4}$ (CO2)

7. A) Solve $2\sin^2\theta - \sin\theta - 1 = 0$ (CO2)
or

B) In any $\triangle ABC$, if $\angle B = 60^\circ$ then $\frac{c}{a+b} + \frac{a}{b+c} = 1$ (CO2)

8. A) Find the equation of circle with $(2,3)$ and $(6,9)$ as the end points of diameter and also find centre and radius of circle. (CO3)
or

B) Find the equation of ellipse whose focus is $(1,-1)$, directrix is $x - y + 3 = 0$ and eccentricity is $1/2$.
(CO3)

-o0o-

Unit Test III

C –20, C -102

State Board of Technical Education and Training, A. P

First Year

Subject name: **Engineering Mathematics-I**

Sub Code: **C-102**

Time : 90 minutes

Max.marks:40

Part-A

16Marks

Instructions: (1) Answer all questions.

(2) First question carries four marks and the remaining questions carry three marks each

1. Answer the following.

a. Find $\lim_{x \rightarrow 1} \frac{x^2 + 1}{x + 5}$ (CO4)

b. $\lim_{\theta \rightarrow 0} \frac{\sin 2\theta}{\theta} = 2$: State TRUE/FALSE (CO4)

c. $\frac{d}{dx}(3 \tan^{-1} x) = ?$ (CO4)

d. Formula for percentage error in X is _____ (CO5)

2. Evaluate $\lim_{x \rightarrow 2} \frac{x^5 - 32}{x^2 - 4}$ (CO4)

3. Find the derivative of $3 \tan x - 4 \log x + 7^x$ w.r.t. x (CO4)

4. Differentiate $x^2 \sin x$ w.r.t. x (CO4)

5. Find the derivative of $\frac{2x+3}{3x+4}$ (CO4)

- Instructions:** (1) Answer all questions.
 (2) Each question carries eight marks
 (3) Answer should be comprehensive and the criterion for valuation is the content but not the length of the answer.

6. A) Find the derivative of $\sin^{-1}\left(\frac{2x}{1+x^2}\right)$ w.r.t. $\tan^{-1}\left(\frac{2x}{1-x^2}\right)$. (CO4)

or

B) Find $\frac{dy}{dx}$ if $y=x^{\cos x}$ (CO4)

7. A) Verify Euler's theorem when $u(x, y) = \frac{x^4 + y^4}{x - y}$ (CO4)

or

B) Find the equation of tangent and normal to the curve $3y = x^2 - 6x + 17$ at $(4, 3)$ (CO5)

8. A) Circular patch of oil spreads on water and the area is growing at the rate of $8\text{sqcm}/\text{min}$. How fast is the radius increasing when radius is 5cm .

(CO5)

or

B) Find the maxima and minima values of $f(x) = x^3 - 6x^2 + 9x + 15$. (CO5)

END-EXAM MODEL PAPERS

**STATE BOARD OF TECHNICAL EDUCATION, A.P
ENGINEERING MATHEMATICS C- 102**

TIME : 3 HOURS

MODEL PAPER- I

MAX.MARKS : 80M

PART-A

Answer All questions. Each question carries THREE marks.

10x3=30M

1. If $A = \left\{0, \frac{\pi}{6}, \frac{\pi}{4}, \frac{\pi}{3}, \frac{\pi}{2}\right\}$ and $f: A \rightarrow B$ is a function such that $f(x) = \cos x$, then find the range of f . **CO 1**

2. Resolve the function $\frac{x}{(x-1)(x-2)}$ into partial fractions. **CO 1**

3. If $A = \begin{bmatrix} 3 & 9 & 0 \\ 1 & 8 & -2 \end{bmatrix}$ and $B = \begin{bmatrix} 4 & 0 & 2 \\ 7 & 1 & 4 \end{bmatrix}$, find $A+B$ and $A-B$. **CO1**

4. Show that $\frac{\cos 16^\circ + \sin 16^\circ}{\cos 16^\circ - \sin 16^\circ} = \tan 61^\circ$. **CO2**

5. Prove that $\frac{\sin 2\theta}{1 - \cos 2\theta} = \cot \theta$. **CO2**

6. Find the modulus of the complex number $\left(\frac{1-i}{2+i}\right)$. **CO2**

7. Find the distance between parallel lines $x+2y+3=0$ and $x+2y+8=0$. **CO3**

8. Find $\lim_{x \rightarrow 0} \frac{\sin 7x}{\sin 11x}$. **CO4**

9. Differentiate $3 \tan x - 4 \log x - 7x^2$ w.r.t. x . **CO4**

10. If $x=at^2, y=2at$, then find $\frac{dy}{dx}$. **CO4**

PART-B

Answer All questions. Each question carries EIGHT marks.

5x8=40M

11 A) Find the inverse of the matrix $\begin{bmatrix} 3 & -3 & 4 \\ 2 & -3 & 4 \\ 0 & -1 & 1 \end{bmatrix}$. **CO1**

Or

B) Solve the system of equations $x+y+z=6, x-y+z=2$ and $2x-y+3z=9$ by

Cramer's rule.

CO1

12 A) If $\cos x + \cos y = \frac{3}{5}$ and $\cos x - \cos y = \frac{2}{7}$, then show that CO2

$$21 \tan\left(\frac{x-y}{2}\right) + 10 \cot\left(\frac{x+y}{2}\right) = 0.$$

Or

B) If $\tan^{-1} x + \tan^{-1} y + \tan^{-1} z = \pi$ then show that $x + y + z = xyz$. CO2

13 A) Solve $\sqrt{3} \cos \theta - \sin \theta = 1$. CO2

Or

B) In any ΔABC , Show that $\cot \frac{A}{2} + \cot \frac{B}{2} + \cot \frac{C}{2} = \frac{s^2}{\Delta}$. CO2

14 A) Find the equation of the circle with $(4, 2)$ and $(1, 5)$ as the two ends of its diameter and also find its centre and radius. CO 3

Or

B) Find the centre, vertices, equation of axes, lengths of axes, eccentricity, foci, equations of directrices and length of latus rectum of the ellipse $4x^2 + 16y^2 = 1$. CO 3

15 A) Find the derivative of $\sin^{-1}\left(\frac{2x}{1+x^2}\right)$ w.r.t. $\tan^{-1}\left(\frac{2x}{1-x^2}\right)$ CO4

Or

B) If $u = \tan^{-1}\left(\frac{x^3 - y^3}{x + y}\right)$, then prove that $x \frac{\partial u}{\partial x} + y \frac{\partial u}{\partial y} = \sin 2u$. CO4

PART-C

Answer the following question. Question carries TEN marks. 1x10=10M

16. The sum of two numbers is 24. Find them so that the sum of their squares is minimum.

CO 5

STATE BOARD OF TECHNICAL EDUCATION, A.P
ENGINEERING MATHEMATICS C- 102

TIME : 3 HOURS

MODEL PAPER- II

MAX.MARKS : 80M

PART-A

Answer All questions. Each question carries THREE marks.

10x3=30M

1. If $f: R \rightarrow R$ is a bijective function such that $f(x) = ax + b$, then find $f^{-1}(x)$. **CO 1**

2. Resolve the function $\frac{1}{(x+1)(x-2)}$ into partial fractions. **CO 1**

3. If $A = \begin{bmatrix} 0 & -1 & 3 \\ 1 & 0 & 7 \\ -3 & x & 0 \end{bmatrix}$ is a skew-symmetric matrix, find the value of x . **CO 1**

4. Find the value of $\sin^2 82\frac{1}{2} - \sin^2 22\frac{1}{2}$. **CO2**

5. Prove that $\frac{\cos 3A}{2\cos 2A - 1} = \cos A$ **CO2**

6. Find the conjugate of the complex number $(3-2i)(4+7i)$. **CO2**

7. Find the equation of the line passing through the points $(1,2)$ and $(3,-4)$. **CO3**

8. Find $\lim_{x \rightarrow 2} \frac{x^5 - 32}{x - 2}$. **CO4**

9. Differentiate $\sqrt{x} - \sec x + \log x$ w.r.t. x . **CO4**

10. If $u(x,y) = x^3 - 3axy + y^3$, then find $\frac{\partial u}{\partial x}$ and $\frac{\partial u}{\partial y}$. **CO4**

PART-B

Answer All questions. Each question carries EIGHT marks. 5x8=40M

11 A) Show that $\begin{vmatrix} 1 & 1 & 1 \\ a & b & c \\ a^2 & b^2 & c^2 \end{vmatrix} = (a-b)(b-c)(c-a)$. **CO1**

Or

B) Solve the system of equations $x + 2y + 3z = 6$, $3x - 2y + 4z = 5$ and $x - y - z = -1$ using matrix inversion method. **CO1**

12 A) Prove that $\frac{\sin 2\theta + \sin 4\theta + \sin 6\theta}{\cos 2\theta + \cos 4\theta + \cos 6\theta} = \tan 4\theta$. **CO2**

Or

B) Prove that $\tan^{-1} \frac{1}{3} + \tan^{-1} \frac{1}{5} + \tan^{-1} \frac{1}{7} + \tan^{-1} \frac{1}{8} = \frac{\pi}{4}$. **CO2**

13 A) Solve $2\cos^2 \theta - 3\cos \theta + 1 = 0$. **CO2**

Or

B) In any ΔABC , Show that $\sum a^3 \cos(B-C) = 3abc$. **CO2**

14 A) Find the equation of the circle passing through the points $(0,0)$, $(6,0)$ and $(0,8)$. **CO3**

Or

B) Find the equation of the rectangular hyperbola whose focus is $(1,2)$ and directrix is

$$3x + 4y - 5 = 0.$$

CO3

15 A) If $\sin y = x \sin(a+y)$, then prove that $\frac{dy}{dx} = \frac{\sin^2(a+y)}{\sin a}$. **CO4**

Or

B) If $y = \tan^{-1} x$, then prove that $(1+x^2)y_2 + 2xy_1 = 0$. **CO4**

PART-C

Answer the following question. Question carries TEN marks. $1 \times 10 = 10M$

16 Show that the semi-vertical angle of the cone of maximum volume and of given slant height is $\tan^{-1} \sqrt{2}$. **CO4**

Course code	Course Title	No. of Periods per week	Total No. of Periods	Marks for FA	Marks for SA
103	Engineering Physics	4	120	20	80

S. No	Unit Title/Chapter	No of Periods	COs Mapped
1	Units and Dimensions	08	CO1
2	Elements of Vectors	12	CO1
3	Dynamics	12	CO2
4	Friction	10	CO2
5	Work, Power and Energy	12	CO3
6	Simple harmonic motion	12	CO3
7	Heat and Thermodynamics	12	CO4
8	Sound	10	CO4
9	Properties of matter	10	CO5
10	Electricity and Magnetism	12	CO5
11	Modern physics	10	CO5
Total		120	

Course Title: Engineering Physics	
Course Objectives	<ol style="list-style-type: none"> 1. To familiarize with the concepts of Physics involved in the process of various Engineering, Industrial and Daily life Applications. 2. To understand and apply the basic principles of physics in the field of engineering and technology to familiarize certain natural phenomenon occurring in the day to day life 3. To reinforce theoretical concepts by conducting relevant experiments/exercises

Course Outcomes	CO1	Explain S.I units and dimensions of different physical quantities, basic operations among vector quantities.
	CO2	Explain the motion of objects moving in one dimension and two dimensions, the causes of motion and hindrance to the motion of the objects especially with respect to friction.
	CO3	Explain the mechanical energy of bodies like PE, KE and conservation law of energy, the properties of simple harmonic motion.
	CO4	Explain gas laws, ideal gas equation, Isothermal and adiabatic processes, Specific heats, to study the laws of thermodynamics. Causes, consequences and methods to minimise noise pollution, explain beats, Doppler effect, Reverberation, echoes.
	CO5	Explain certain properties of solids, liquids like elastic properties, viscosity and surface tension. Explain Ohm's law, to study Kirchoff's laws, to study the principle of Wheatstone's bridge and its application to meter bridge. To study the magnetic force and understand magnetic field. To compute magnetic field strength on axial and equatorial lines of a bar magnet. To familiarise with modern topics like photoelectric effect, optical fibres, superconductivity and nanotechnology.

COS, POS, PSOS MAPPING

➤ POs mapping strength (as per given table)

	PO1	PO2	PO3	PO4	PO5	PO6	PO7	PSO1	PSO2	PSO3
CO1	3					1		1	1	1
CO2	3		2					1	1	
CO3	3		2					1		
CO4	3	2			2				2	2
CO5	3			2			2	1	1	

3 = strongly mapped 2= moderately mapped 1= slightly mapped

Note:

The gaps in CO and PO mapping will be achieved by one or more appropriate activities from the following:

- i) Seminars ii) Tutorials iii) Guest lectures iv) Assignments v) Quiz competitions vi) Industrial visits vii) Tech Fest viii) Mini project ix) Group discussion x) Virtual classes xi) Library visit for e-books

Learning Outcomes

1.0 Concept of Units and dimensions

- 1.1 Explain the concept of Units, Physical quantity, Fundamental physical quantities and Derived physical quantities
- 1.2 Define unit, fundamental units and derived units, State SI units with symbols
- 1.3 State Multiples and submultiples in SI system, State Rules of writing S.I. units, State advantages of SI units
- 1.4 Define Dimensions, Write Dimensional formulae of physical quantities
- 1.5 List dimensional constants and dimensionless quantities
- 1.6 State the principle of homogeneity of dimensions
- 1.7 State the applications and limitations of dimensional analysis
- 1.8 Errors in measurement, Absolute error, relative error, percentage error, significant figures
- 1.9 Solve problems

2.0 Concept of Elements of Vectors

- 2.1 Explain the concept of scalars, Vectors and give examples
- 2.2 Represent vectors graphically, Classify the Vectors, Resolve the vectors
- 2.3 Determine the resultant of a vector by component method, represent a vector in Space using unit vectors (i, j, k)
- 2.4 State and explain triangle law, parallelogram law, and polygon law of addition of Vectors
- 2.5 Define Dot product of two vectors with examples (Work done, Power), mention the Properties of dot product
- 2.6 Define cross product of two vectors with examples (Torque, Linear velocity) Mention the properties of Cross product.
- 2.7 Solve the related numerical problems

3.0 Concept of Dynamics

- 3.1 Write the equations of motion in a straight line. Explain the acceleration due to Gravity.
- 3.2 Explain vertical motion of a body and derive expressions for a) Maximum Height, b) Time of ascent, c) time of descent, and d) time of flight
- 3.3 Derive height of a tower when a body projected vertically upwards from the top of a tower.
- 3.4 Explain projectile motion with examples
- 3.5 Explain horizontal projection and derive an expression for the path of a projectile in horizontal projection
- 3.6 Explain oblique projection and derive an expression for it. Derive formulae for a) Maximum Height b) time of ascent c) time of descent and d) time of flight e) Horizontal Range, f) Maximum range
- 3.7 Define force, momentum, angular displacement, angular velocity, angular acceleration, angular momentum, moment of inertia, torque
- 3.8 Solve the related numerical problems

4.0 Concept of Friction

- 4.1 Define friction and classify the types of friction.
- 4.2 Explain the concept of normal reaction.
- 4.3 State the laws of friction.
- 4.4 Define coefficients of friction, Angle of friction and angle of repose.
- 4.5 Derive expressions for acceleration of a body on a rough inclined plane. (Upwards and downwards)
- 4.6 List the advantages and disadvantages of friction.
- 4.7 Mention the methods of minimizing friction.
- 4.8 Explain why it is easy to pull a lawn roller than to push it.
- 4.9 Solve the related numerical problems.

5.0 Concepts of Work, Power, and Energy

- 5.1 Define the terms Work, Power and Energy. State SI units and dimensional Formulae.
- 5.2 Define potential energy and give examples, derive an expression for potential energy.
- 5.3 Define Kinetic energy and give examples, derive an expression for kinetic energy.
- 5.4 State and derive Work-Energy theorem.
- 5.5 Derive the relation between Kinetic energy and momentum.
- 5.6 State the law of conservation of energy and verify it in the case of a freely falling body.
- 5.7 Solve the related numerical problems.

6.0 Concepts of Simple harmonic motion

- 6.1 Define Simple harmonic motion, Give examples, state the conditions.
- 6.2 Explanation of uniform circular motion of a particle is a combination of two perpendicular S.H.M.s.
- 6.3 Derive expressions for displacement, velocity, acceleration, Frequency, Time period of a particle executing SHM.
- 6.4 Define phase of SHM.
- 6.5 Define Ideal simple pendulum and derive expression for time period of simple pendulum.
- 6.6 State the laws of motion of simple pendulum.
- 6.7 Solve the related numerical problems.

7.0 Concept of heat and thermodynamics

- 7.1 Explain the concept of expansion of gases
- 7.2 State and explain Boyle's and Charles laws.
- 7.3 Define absolute zero temperature, absolute scale of temperature
- 7.4 Define ideal gas and distinguish from real gas
- 7.5 Derive Ideal gas equation. Define specific gas constant and universal gas constant, write S.I unit and dimensional formula. Calculate the value of R.
- 7.6 Explain why universal gas constant is same for all gases
- 7.7 State and explain isothermal process and adiabatic process
- 7.8 State first and second laws of thermodynamics and state applications
- 7.9 Define specific heats and molar specific heats of a gas, Derive $C_p - C_v = R$
- 7.10 Solve the relevant numerical problems

8.0 Concept of Sound

- 8.1 Concept of the sound, Wave motion. (longitudinal and transverse wave)
- 8.2 Distinguish between musical sound and noise.
- 8.3 Explain noise pollution and state SI unit for intensity level of sound.
- 8.4 Explain causes, effects and methods of minimizing of noise pollution.
- 8.5 Explain the phenomenon of beats state the applications.
- 8.6 Define Doppler effect, list the applications.
- 8.7 Define reverberation and reverberation time and write Sabine's formula.
- 8.8 Define and explain echoes state its applications.
- 8.9 State conditions of good auditorium.
- 8.10 Solve the related numerical problems.

9.0 Concepts of properties of matter

- 9.1 Explain the terms elasticity, stress, strain and types of stress and strain.
- 9.2 State and explain Hooke's law.
- 9.3 Definitions of Modulus of elasticity, Young's modulus (Y), Bulk modulus (K), Rigidity modulus (n), Poisson's ratio (σ),
- 9.4 Define surface tension and give examples.
- 9.5 Explain Surface tension with reference to molecular theory.
- 9.6 Define angle of contact and capillarity and write formula for Surface Tension.
- 9.7 Explain the concept of viscosity, give examples, write Newton's formula.
- 9.8 Define co-efficient of viscosity and write its units and dimensional formula and State Poiseuille's equation for Co-efficient of viscosity.
- 9.9 Explain the effect of temperature on viscosity of liquids and gases.
- 9.10 Solve the related numerical problems.

10. Concepts of Electricity and Magnetism

- 10.1 Explain Ohm's law in electricity and write the formula.
- 10.2 Define specific resistance, conductance and state their units.
- 10.3 Explain Kichoff's laws.
- 10.4 Describe Wheatstone's bridge with legible sketch.
- 10.5 Describe Meter Bridge for the determination of resistivity with a circuit diagram.
- 10.6 Explain the concept of magnetism. State the Coulomb's inverse square law of Magnetism.
- 10.7 Define magnetic field and magnetic lines of force and write the properties of magnetic lines of force.
- 10.8 Derive an expression for the moment of couple on a bar magnet placed in a uniform magnetic field.
- 10.9 Derive equations for Magnetic induction field strength at a point on the axial line and on the equatorial line of a bar magnet.
- 10.10 Solve the related numerical problems

11.0 Concepts of modern physics

- 11.1 State and explain Photo-electric effect and Write Einstein's photo electric Equation.
- 11.2 State laws of photo electric effect.
- 11.3 Explain the Working of photo electric cell, write its applications.
- 11.4 Recapitulation of refraction of light and its laws, critical angle, total Internal Reflection.
- 11.5 Explain the principle and working of Optical fiber, mention different types of Optical fiber, state the applications.
- 11.6 Define super conductor and super conductivity and mention examples.
- 11.7 State the properties of super conducting materials and list the applications.
- 11.8 Nanotechnology definition, nano materials, applications.

COURSECONTENT

1. Units and Dimensions:

Introduction, Physical quantity, Fundamental and Derived quantities, Fundamental and Derived units, SI units, Multiples and Sub multiples, Rules for writing S.I. units, Advantages of SI units. Dimensions and Dimensional formulae, Dimensional constants and Dimensionless quantities, Principle of homogeneity, Advantages and limitations of dimensional analysis, Errors in measurement, Absolute error, relative error, percentage error, significant figures, Problems.

2. Elements of Vectors:

Scalars and Vectors, Types of vectors (Proper Vector, Null Vector, Unit Vector, Equal, Negative Vector, Like Vectors, Co-Initial Vectors, Co-planar Vectors and Position Vector). Addition of vectors, Representation of vectors, Resolution of vectors, Parallelogram, Triangle and Polygon laws of vectors, Subtraction of vectors, Dot and Cross products of vectors-Problems.

3. Dynamics

Introduction-Concept of acceleration due to gravity-Equations of motion for a freely falling body and for a body thrown up vertically- Projectiles- Horizontal and Oblique projections- Expressions for maximum height, time of flight, range-Define force, momentum, angular displacement, angular velocity, angular acceleration, angular momentum, moment of inertia, torque-problems.

4. Friction:

Introduction to friction- Causes- Types of friction- Laws of friction- Angle of repose-Angle of friction- rough inclined plane- Advantages and disadvantages of friction-Methods of reducing friction-Problems.

5. Work, Power and Energy:

Work, Power and Energy- Definitions and explanation- potential energy- kinetic energy- Derivations of Potential and Kinetic energies-K.E and Momentum relation - Work-Energy theorem- Law of Conservation of energy- Problems.

6. Simple Harmonic Motion:

Introduction- Conditions of SHM- Definition- Examples- Expressions for displacement, velocity, acceleration, Time period, frequency and phase in SHM- Time period of a simple pendulum- Laws of simple pendulum-seconds pendulum-Problems.

7. Heat and Thermodynamics:

Expansion of Gases, Boyle's law, absolute scale of temperature- Charles laws- Ideal gas equation- Universal gas constant- Differences between gas constant(r) and universal gas constant(R), Isothermal and adiabatic processes, Laws of thermodynamics, Specific heats - molar specific heats of a gas -Different modes of transmission of heat ,laws of thermal conductivity, Coefficient of thermal conductivity-Problems.

8. Sound:

Sound- Nature of sound- Types of wave motion -musical sound and noise- Noise pollution – Causes & effects- Methods of reducing noise pollution- Beats- Doppler effect- Echo- Reverberation-Reverberation time-Sabine 's formula-Conditions of good auditorium-Problems.

9. Properties of matter

Definition of Elasticity –Definition of stress and strain -the units and dimensional formulae for stress and strain-The Hooke's law-Definitions of Modulus of elasticity, Young's modulus(Y), Bulk modulus(K), Rigidity modulus (n),Poisson's ratio (σ), relation between Y, K, n and σ (equations only no derivation)

Definition of surface tension-Explanation of Surface tension with reference to molecular theory - Definition of angle of contact -Definition of capillarity -The formula for surface tension based on capillarity - Explanation of concept of Viscosity - Examples for surface tension and Viscosity - Newton's formula for viscous force- Definition of co-efficient of viscosity- The effect of temperature on viscosity of liquids and gases - Poiseuille's equation for Co-efficient of viscosity- The related numerical problems.

10. Electricity & Magnetism:

Ohm's law and explanation, Specific resistance, Kirchoff's laws, Wheatstone's bridge, Meter bridge, Coulomb's inverse square law, magnetic field, magnetic lines of force, magnetic induction field strength- magnetic induction field strength at a point on the axial line - magnetic induction field strength at a point on the equatorial line–problems.

11. Modern Physics;

Photoelectric effect –Einstein's photoelectric equation-laws of photoelectric effect-photoelectric cell–Applications of photo electric effect- Total internal reflection- fiber optics- principle and working of an optical fiber-types of optical fibers - Applications of optical fibers- superconductivity–applications-Nanotechnology definition, nano materials, applications

REFERENCEBOOKS

1. Telugu Academy (English version)	Intermediate physics Volume-I & 2
2. Dr. S. L. Gupta and Sanjeev Gupta	Unified physics Volume 1,2,3 and 4
3. Resnick& Holiday	Text book of physics Volume I
4. Dhanpath Roy	Text book of applied physics
5. D.A Hill	Fiber optics
6. XI & XII Standard	NCERT Text Books

➤ **Model Blue Print with Weightage for Blooms category and questions for chapter and Cos mapped**

S. No	Unit Title/Chapter	No of Periods	Weight age of marks	Marks wise distribution of Weightage				Question wise distribution of Weightage				Mapped with CO
				R	U	Ap	An	R	U	Ap	An	
1	Units and Dimensions	08	03	3	0	0	0	1	0	0	0	CO1
2	Elements of Vectors	12	11	3	8	0	0	1	1	0	0	CO1
3	Dynamics	12	11	3	8	0	0	1	1	0	*	CO2
4	Friction	10	11	3	0	8	0	1	0	1	0	CO2
5	Work, Power and Energy	12	11	3	8	0	0	1	1	0	0	CO3
6	Simple harmonic motion	12	11	3	8	0	0	1	1	0	*	CO3
7	Heat and Thermodynamics	12	11	0	8	3	0	0	1	1	*	CO4
8	Sound	10	11	0	8	3	0	0	1	1	0	CO4
9	Properties of matter	10	08	0	8	0	0	0	1	0	0	CO5
10	Electricity and Magnetism	12	14	6	0	8	0	2	0	1	0	CO5
11	Modern physics	10	08	0	8	0	0	0	1	0	0	CO5
Total		120	110	24	64	22	0	8	8	4	* 10	

*One question of HOTs for 10 marks from any of the unit title 3 or 6 or 7

➤ **Table specifying the scope of syllabus to be covered for Unit Tests**

Unit Test	Learning outcomes to be covered
Unit Test – 1	From 1.1 to 4.9
Unit Test – 2	From 5.1 to 7.10
Unit Test – 3	From 8.1 to 11.8

- Model question paper for Unit Tests I,II,III with COs mapped

UNIT TEST –I
Model Question Paper (C-20)
ENGINEERING PHYSICS (103)

TIME: 90 minutes

Total Marks: 40

PART-A

16 Marks

Instructions: (1) Answer all questions.

(2) First question carries 4 marks and others carry 3 marks each.

(3) Answers for the Question numbers 2 to 5 should be brief and straight to the point and shall not exceed five simple sentences.

1. i) The dimensional formula of force is _____ (CO1)
ii) Which of the following is a scalar [](CO1)
a) force b) work c) displacement d) velocity
- iii) we can add a scalar to a vector (Yes / No) (CO1)
iv) Friction is a self-adjusting force. [True / False] (CO2)
2. Define dot product. Give one example.(CO1)
3. A force of 150 N acts on a particle at an angle of 30° to the horizontal. Find the horizontal and vertical components of force.(CO1)
4. Define projectile. Give two examples.(CO2)
5. It is easier to pull a lawn roller than to push it. Explain (CO2)

PAR

T—B

3x8=24

Instructions: (1) Answer all questions. Each question carries 8marks.

(2) Answer should be comprehensive and the criteria for evaluation is content but not the length of the answer.

- 6) (A) Derive an expression for magnitude and direction of resultant of two Vectors using parallelogram law of vectors (CO1)

OR

(B) Write any four properties of dot product and any four properties of Cross product (CO1)

- 7) (A) Show that path of a projectile is a parabola in case of oblique Projection. (CO2)

OR

(B) Derive the expression for range and time of flight of a projectile (CO2)

- 8) (A) State and explain polygon law of vector addition with a neat diagram(CO1)

OR

(B) Derive the equation for acceleration of a body on a rough inclined plane(CO2)

UNIT TEST –II
Model Question Paper (C-20)
ENGINEERING PHYSICS (C–103)

TIME: 90 minutes

Total Marks: 40

PART –A

16 Marks

Instructions: (1) Answer all questions.

(2) First question carries 4 marks and others carry 3 marks each.

(3) Answers for the Question numbers 2 to 5 should be brief and

Straight to the point and shall not exceed five simple sentences.

- 1) i) The value of 100°C is equal to _____ in Kelvin scale of temperature **(CO4)**
- ii) Write the S.I unit of power **(CO3)**
- iii) A simple pendulum be used in artificial satellite (Yes / No) **(CO3)**
- iv) Specific heat of a gas is constant for all gases in nature [True / False]**(CO4)**
2. Derive the relation between momentum and kinetic energy**(CO3)**
3. A girl is swinging by sitting in a swing, how the frequency changes if she stands in the swing.**(CO3)**
4. Write the physical significance of universal gas constant. **(CO4)**
5. A body is projected in to the air in the vertically upward direction, find the height at which its potential and kinetic energies are equal. **(CO3)**

PART—B

3x8=24 Marks

Instructions: (1) Answer all questions. Each question carries 8marks.

(2) Answer should be comprehensive and the criteria for

evaluation is content but not the length of the answer.

- 6) (A) State the law of conservation of energy and verify it in case of a freely falling body.**(CO3)**
(OR)
(B) State and prove work energy theorem. **(CO3)**
- 7) (A) Define ideal simple pendulum and derive the equation for time period of a simple pendulum **(CO3)**
OR
(B) State the conditions for S.H.M, derive the equation for velocity for a Particle in S.H.M. **(CO3)**
- 8) (A) Define ideal gas, show that for an ideal gas the difference in specific heats is equal to universal gas constant**(CO4)**
(OR)
(B) State gas laws and derive the ideal gas equation**(CO4)**

UNIT TEST –III
Model Question Paper (C-20)
ENGINEERING PHYSICS (C–103)

TIME: 90 minutes

Total Marks: 40

PART –A

16 Marks

Instructions: (1) Answer all questions.

(2) First question carries 4 marks and others carry 3 marks each.

(3) Answers for the Question numbers 2 to 5 should be brief and straight to the point and shall not exceed five simple sentences.

- 1) i) Photo electric cell converts light energy in to _____ energy **(CO5)**
ii) What is elastic limit ?**(CO5)**
iii) SI unit of Specific resistance is ----- **(CO5)**
iv) Inside a bar magnet magnetic line of force will travel from North pole to South pole [True / False] **(CO5)**
2. Distinguish between Musical sound and Noise **(CO4)**
3. What is the effect of temperature on Viscosity of liquids and gases**(CO5)**
4. The values of resistances P, Q, R are 50 Ω , 10 Ω , 15 Ω respectively in the balanced condition of Wheatstone bridge, find the unknown resistance**(CO5)**
5. What is nanotechnology and write any two uses. **(CO5)**

PART—B

3x8=24 Marks

Instructions: (1) Answer all questions. Each question carries 8marks.

(2) Answer should be comprehensive and the criteria for evaluation is content but not the length of the answer.

- 6) (A) Explain Surface Tension based on the molecular theory **(CO5)**
(OR)
(B) Define Reverberation and Reverberation Time. Derive Sabine formula for reverberation time.**(CO4)**
- 7) (A) Derive the balancing condition of Wheatstone bridge with neat circuit Diagram. **(CO5)**
(OR)
(B) Derive an expression for the magnetic induction field strength at a point on the equatorial line of a bar magnet.**(CO5)**
- 8) (A) Describe an experiment to determine the specific resistance of a wire using meter bridge.**(CO5)**
(OR)
(B) Explain the principle and working of an optical fiber. **(CO5)**

BOARD DIPLOMA EXAMINATION, (C-20)
FIRST YEAR EXAMINATION
C-103, ENGINEERING PHYSICS

Time : 3 hours]

[Total Marks : 80M

PART—A

3×10=30

Instructions: (1) Answer all questions.
(2) Each question carries three marks.
(3) Answers should be brief and straight to the point and shall not exceed five simple Sentences.

1. Write the dimensional formula of the following physical quantities **(CO1)**
(a) Velocity (b) Force (c) Angular momentum
2. Write any three properties of scalar product. **(CO1)**
3. Define projectile. Give two examples. **(CO2)**
4. It is easier to pull a lawn roller than to push it. Explain. **(CO2)**
5. Define potential energy and kinetic energy. **(CO3)**
6. For a body in simple harmonic motion velocity at mean position is 4m/s, if the time period is 3.14 s, find its amplitude. **(CO3)**
7. State first and second laws of thermodynamics. **(CO4)**
8. Write any three conditions of good auditorium **(CO4)**
9. Define ohmic and non-ohmic conductors. **(CO5)**
10. State Coulomb's inverse square law of magnetism. **(CO5)**

PART—B

8 ×5= 40

Instructions: (1) Each question carries eight marks.
(2) Answers should be comprehensive and the criterion for valuation is the content
But not the length of the answer.

11. A) Derive an expression for magnitude and direction of the resultant of two vectors using Parallelogram law of vectors. **(CO1)**

OR

B) Show that path of a projectile is parabola in case of oblique projection and derive expression for maximum height. **(CO2)**

12. A) Derive expression for acceleration of a body sliding downwards on a rough inclined plane. **(CO2)**

OR

B) Verify the law of conservation of energy in case of a freely falling body. **(CO3)**

13. A) Derive an expression for velocity and acceleration of a particle performing simple harmonic Motion. **(CO3)**

OR

B) Define ideal gas and derive ideal gas equation. **(CO4)**

14. A) Two tuning forks A and B produce 4 beats per second. On loading B with wax 6 beats are produced. If the quantity of wax is reduced the number of beats drops to 4. If the frequency of A is 326 Hz, find the frequency of B. **(CO4)**

OR

B) Explain surface tension based on molecular theory. Write three examples of surface tension. **(CO5)**

15. A) Derive an expression for balancing condition of Wheat stone's bridge with a neat circuit diagram. **(CO5)**

OR

B) Explain principle and working of optical fibers. Write any three applications. **(CO5)**

PART C

1 x 10 = 10

16) Derive relationship between molar specific heat of a gas at constant pressure C_p and molar specific heat of a gas at constant volume C_v and hence show that C_p is greater than C_v . **(CO4)**

Course code	Course Title	No. of Periods per week	Total No. of Periods	Marks for FA	Marks for SA
104	Engineering Chemistry and Environmental Studies	4	120	20	80

S.No	Unit Title/Chapter	No of Periods	COs Mapped
1	Fundamentals of Chemistry	18	CO1
2	Solutions	10	CO1
3	Acids and bases	10	CO1
4	Principles of Metallurgy	8	CO1
5	Electrochemistry	16	CO2
6	Corrosion	8	CO2
7	Water Treatment	10	CO3
8	Polymers	12	CO4
9	Fuels	6	CO4
10	Chemistry in daily life	6	CO4
11	Environmental Studies	16	CO5
	Total	120	

➤ **Course Objectives**

Course Title: Engineering Chemistry & Environmental Studies	
Course Objectives	<ol style="list-style-type: none"> 1. To familiarize with the concepts of chemistry involved in the process of various Engineering Industrial Applications. 2. To know the various natural and man-made environmental issues and concerns with an interdisciplinary approach that include physical, chemical, biological and socio cultural aspects of environment. 3. To reinforce theoretical concepts by conducting relevant experiments/exercises

➤ **Course outcomes**

Course Outcomes	CO1	Explain Bohr's atomic model, chemical bonding, mole concept, acids and bases, P ^H metallurgical process and alloys
	CO2	Explain electrolysis, Galvanic cell, emf and corrosion
	CO3	Explain the chemistry involved in the treatment of water by advanced method
	CO4	Synthesise of Plastics, rubber and applications of fuel chemical compounds used in our daily life.
	CO5	Explain the causes, effects and control methods of air and water pollution and measures to protect the environment

Course code C-104	Engg. Chemistry and Environmental studies No of Cos;5			No Of periods 120	
POs	Mapped with CO No	CO periods addressing PO in Col 1 NO	%	Level 1,2,3	remarks
PO1	CO1,CO2,CO3, CO4,CO5	60	50%	3	>40% level 3 (highly addressed) 25% to 40% level2(moderately addressed 5% to 25% level1 (Low addressed < 5%(not addressed)
PO2	CO1,CO2	13	10.8%	1	
PO3	CO2,CO3	10	8.3%	1	
PO4	CO1	10	8.3%	1	
PO5	CO4,CO5	15	12.5	1	
PO6					
PO7	CO4	12	10%	1	

➤ COs-POs mapping strength (as per given table)

	PO1	PO2	PO3	PO4	PO5	PO6	PO7	PSO1	PSO2	PSO3
CO1	3	1		1				1	1	
CO2	3	1	2					1	1	
CO3	3		2							
CO4	3				1		2			
CO5	3				3			1		

3 = strongly mapped

2= moderately mapped

1= slightly mapped

Note: The gaps in CO and PO mapping will be achieved by one or more appropriate activities from the following:

- i) Seminars ii) Tutorials iii) Guest Lectures iv) Assignments v) Quiz competitions vi) Industrial visit vii) Tech Fest viii) Mini project ix) Group discussions x) Virtual classes xi) Library visit for e-books

➤ **Model Blue Print with Weightage for Blooms category and questions for each chapter and COs mapped**

S.No	Unit Title/Chapter	No of Periods	Weight age of marks	Marks wise distribution of Weightage				Question wise distribution of Weightage				Mapped with CO
				R	U	Ap	An	R	U	Ap	An	
1	Fundamentals of Chemistry	18	19	8	8	3		1	1	1		CO1
2	Solutions	10	11	0	0	8	3			1	1	CO1
3	Acids and bases	10	11	0	8	0	3		1		1	CO1
4	Principles of Metallurgy	8	8	8	0	0		1				CO1
5	Electrochemistry	16	11	8	3	0		1	1		*	CO2
6	Corrosion	8	8	0	8	0			1			CO2
7	Water Treatment	10	11	8	3	0		1	1			CO3
8	Polymers	12	11	3	8	0		1	1		*	CO4
9	Fuels	6	3	3	0	0		1				CO4
10	Chemistry in daily life	6	3	0	0	3				1		CO4
11	Environmental Studies	16	14	3	11	0		1	2			CO5
Total		120	110	12	6	6	6	20	35	5	* 10	

*One question of HOTs for 10 marks from any of the unit title 5 or 8

Upon completion of the course the student shall be able to learn out

ENGINEERING CHEMISTRY AND ENVIRONMENTAL STUDIES

1.0 Atomic structure

- 1.1 Explain the charge, mass of fundamental particles of an atom (electron, proton and neutron) and the concept of atomic number and mass number.
- 1.2 State the Postulates of Bohr's atomic theory and its limitations.
- 1.3 Explain the significance of four Quantum numbers.
- 1.4 Explain 1. Aufbau principle, 2 Pauli's exclusion principle 3 Hund's rule.
- 1.5 Define Orbital of an atom and draw the shapes of s, p and d- Orbitals.
- 1.6 Write the electronic configuration of elements up to atomic number 30
- 1.7 Explain the significance of chemical bonding
- 1.8 Explain the Postulates of Electronic theory of valency
- 1.9 Define and explain Ionic and Covalent bonds with examples of NaCl, MgO, *H₂, *O₂ and *N₂. (* Lewis dot method)
- 1.10 List out the Properties of Ionic compounds and covalent compounds and distinguish between their properties.
- 1.11 Structures of ionic solids-define a) Unit cell b) co-ordination number and the structures of NaCl and CsCl unit cells.

2.0 Solutions

- 2.1 Define the terms 1. Solution, 2. Solute and 3. Solvent
- 2.2 Classify solutions based on physical state and solubility
- 2.3 Define mole and problems on mole concept.
- 2.4 Define the terms 1. Atomic weight, 2. Molecular weight and 3. Equivalent weight and calculate Molecular weight and Equivalent weight of the given acids. (HCl, H₂SO₄, H₃PO₄) Bases (NaOH, Ca(OH)₂, Al(OH)₃) and Salts (NaCl, Na₂CO₃, CaCO₃)
- 2.5 Define molarity and normality and numerical problems on molarity and normality
 - a) Calculate the Molarity or Normality if weight of solute and volume of solution are given
 - b) Calculate the weight of solute if Molarity or normality with volume of solution are given
 - c) Problems on dilution to convert high concentrated solutions to low concentrated Solutions

3.0 Acids and bases

- 3.1 Explain Arrhenius theory of Acids and Bases and give the limitations of Arrhenius theory of Acids and Bases.
- 3.2 Explain Bronsted–Lowry theory of acids and bases and give the limitations of Bronsted–Lowry theory of acids and bases.
- 3.3 Explain Lewis theory of acids and bases and give the limitations of Lewis theory of acids and bases.
- 3.4 Explain the Ionic product of water
- 3.5 Define pH and explain P^H scale and solve the Numerical problems on pH (Strong Acids and Bases)
- 3.6 Define and explain buffer solution and give the examples of buffer solutions.
- 3.7 State the application of buffer solutions

4.0 Principles of Metallurgy

- 4.1 List out the Characteristics of Metals and non-metals
- 4.2 Distinguish between Metals and Non-metals
- 4.3 Define the terms 1. Mineral, 2. Ore, 3. Gangue, 4. Flux 5. Slag
- 4.4 Describe the methods of concentration of Ore; 1. Handpicking, 2. Levigation and 3. Froth Floatation
- 4.5 Describe the methods involved in extraction of crude metal- Roasting, Calcination and Smelting.
- 4.6 Explain the purification of Copper by Electrolytic Refining
- 4.7 Define an Alloy and Write the composition and uses of the following alloys. 1. Brass 2. German silver 3. Nichrome.

5.0 Electrochemistry

- 5.1 Define the terms 1. Conductor 2. Semiconductor 3. Insulator, 4. Electrolyte 5. Non–electrolyte. Give two examples each.
- 5.2 Distinguish between metallic conduction and Electrolytic conduction
- 5.3 Explain electrolysis by taking example fused NaCl
- 5.4 Explain Faraday's laws of electrolysis
- 5.5 Define 1. Chemical equivalent (E) 2. Electrochemical equivalent (e) and their relation.
- 5.6 Solve the Numerical problems on Faraday's laws of electrolysis and applications of electrolysis (Electro plating)
- 5.7 Define Galvanic cell and explain the construction and working of Galvanic cell.
- 5.8 Distinguish between electrolytic cell and galvanic cell
- 5.9 Explain the electrode potentials and standard electrode potentials

- 5.10 Explain the electrochemical series and its significance
- 5.11 Explain the emf of a cell and solve the numerical problems on emf of the cell based on standard electrode potentials.
- 6.0 Corrosion**
- 6.1 Define the term corrosion.
- 6.2 state the Factors influencing the rate of corrosion
- 6.3 Describe the formation of a) composition cell b) stress cell c) concentration cell during corrosion.
- 6.4 Define rusting of iron and explain the mechanism of rusting of iron.
- 6.5 Explain the methods of prevention of corrosion
- a) Protective coatings (anodic and cathodic coatings)
- b) Cathodic protection (Sacrificial anode process and Impressed–voltage process)
- 7.0 Water Treatment**
- 7.1 Define soft water and hard water with respect to soap action.
- 7.2 Define and classify the hardness of water.
- 7.3 List out the salts that causing hardness of water (with Formulae)
- 7.4 State the disadvantages of using hard water in industries.
- 7.5 Define Degree of hardness and units of hardness (mg/L) or(ppm).
- 7.6 Explain the methods of softening of hard water: a) Ion-exchange process, b)Permutit process or zeolite process
- 7.7 State the essential qualities of drinking water.
- 7.8 Chemistry involved in treatment of water (Coagulation, Chlorination, deflouridation)
- 7.9 Explain Osmosis and Reverse Osmosis with examples.
- 7.10 State the applications of Reverse Osmosis.
- 8.0 Polymers**
- 8.1 Explain the concept of polymerisation
- 8.2 Describe the methods of polymerization a)addition polymerization of ethylene b)condensation polymerization of Bakelite(Only flow chart)
- 8.3 Define thermoplastics and thermosetting plastics with examples.
- 8.4 Distinguish between thermo plastics and thermosetting plastics
- 8.5 List the Characteristics of plastics and state the disadvantages of using plastics.
- 8.6 State the advantages of plastics over traditional materials.
- 8.7 Explain the methods of preparation and uses of the following plastics:
1. PVC, 2.Teflon, 3. Polystyrene 4. Nylon 6,6
- 8.8 Explain processing of Natural rubber and write the structural formula of Natural rubber.
- 8.9 List the Characteristics of raw rubber
- 8.10 Define and explain Vulcanization and List out the Characteristics of Vulcanized rubber.
- 8.11 Define the term Elastomer and describe the preparation and uses of the following synthetic rubbers a) Buna-s and b)Neoprene rubber.
- 9.0 Fuels**
- 9.1 Define the term fuel
- 9.2 Classify the fuels based on physical state and based on occurrence.
- 9.3 List the characteristics of good fuel.
- 9.4 State the composition and uses of gaseous fuels.
a)water gas b) producer gas, c) natural gas, d) Coal gas, e)Biogas.

10.0 Chemistry in daily life

- 10.1 Give the basic chemical composition, applications, health aspects and pollution impacts of
a) soaps, and detergents b) vinegar c) Insect repellents d) activated charcoal e) Soft drinks

11.0 ENVIRONMENTAL STUDIES

- 11.1 Define the term environment and explain the scope and importance of environmental studies
- 11.2 Define the segments of environment 1).Lithosphere, 2).Hydrosphere, 3).Atmosphere, 4).Biosphere,
- 11.3 Define the following terms 1)Pollutant, 2).Pollution, 3).Contaminant, 4)receptor, 5)sink, 6) particulates, 7)dissolved oxygen (DO), 8)Threshold limit value (TLV), 9).BOD,10).COD 11) eco system 12) Producers 13) Consumers 14) Decomposers with examples
- 11.4 State the renewable and non renewable energy sources with examples.
- 11.5 Explain biodiversity and threats to biodiversity
- 11.6 Define air pollution and classify the air pollutants-based on origin and physical state of matter.
- 11.7 Explain the causes, effects of air pollution on human beings, plants and animals and control methods of air pollution.
- 11.8 State the uses of forest resources.
- 11.9 Explain causes and effects of deforestation
- 11.10 Explain the causes and effects of the following
1.) Greenhouse effect, 2) Ozone layer depletion and 3) Acid rain
- 11.11 Define Water pollution, explain the causes, effects and control methods of Water pollution.

COURSE CONTENT

ENGINEERING CHEMISTRY AND ENVIRONMENTAL STUDIES

1. Fundamentals of Chemistry

Atomic Structure: Introduction - Fundamental particles – Bohr's theory – Quantum numbers –Aufbau principle - Hund's rule - Pauli's exclusion Principle- Orbitals, shapes of s, p and d orbitals - Electronic configurations of elements

Chemical Bonding: Introduction – types of chemical bonds – Ionic and covalent bond with examples–Properties of Ionic and Covalent compounds- structures of ionic crystals (NaCl and CsCl).

2. Solutions

Introduction of concentration methods – mole concept, molarity and normality – Numerical problems on mole, molarity and normality.

3. Acids and Bases

Introduction – Theories of acids and bases and limitations – Arrhenius theory- Bronsted – Lowry theory – Lewis acid base theory – Ionic product of water- pH related numerical problems–Buffer solutions, action of buffer and its applications.

4. Principles of Metallurgy

Characteristics of Metals and non-metals –Distinguish between Metals and Non-metals, Define the terms i) Metallurgy ii) ore iii) Gangue iv) flux v) Slag - Concentration of Ore –Hand picking, Levigation, Froth floatation – Methods of Extraction of crude Metal – Roasting, Calcination, Smelting – Alloys – Composition and uses of brass, German silver and nichrome.

5. Electrochemistry

Conductors, semiconductors, insulators, electrolytes and non-electrolytes – electrolysis – Faraday's laws of electrolysis-application of electrolysis(electroplating) -numerical problems on Faraday's laws – Galvanic cell – standard electrode potential – electrochemical series–emf and numerical problems on emf of a cell .

6. Corrosion

Introduction - factors influencing corrosion - composition, stress and concentration cells– rusting of iron and its mechanism – prevention of corrosion by coating methods, cathodic protection methods.

7. Water technology

Introduction–soft and hard water–causes of hardness–types of hardness –disadvantages of hard water – degree of hardness (ppm and mg/lit) – softening methods – permutit process – ion exchange process– qualities of drinking water –Chemistry involved in treatment of water (Coagulation, Chlorination, defluoridation) - Osmosis, Reverse Osmosis –Applications of Reverse osmosis.

8. Polymers

Introduction – polymerization – types of polymerization – addition, condensation with examples – plastics – types of plastics – advantages of plastics over traditional materials- Disadvantages of using plastics – Preparation and uses of the following plastics i).PVC ii) Teflon iii) Polystyrene iv) .Nylonn 6,6 –Processing of natural rubber - Vulcanization – Elastomers- Preparation and applications of Buna-s, Neoprene rubbers.

9. Fuels

Definition and classification of fuels–characteristics of good fuel-composition and uses of gaseous fuels.

10. Chemistry in daily life

Basic composition, applications, health aspects and pollution impacts of soaps and detergents, vinegar, insect repellents, soft drinks, activated charcoal.

11. ENVIRONMENTALSTUDIES

Introduction– environment –scope and importance of environmental studies – important terms related to environment– renewable and non-renewable energy sources–Concept of ecosystem – Biotic components –Forest resources – Deforestation -Biodiversity and its threats-Air pollution – causes-effects–Global environmental issues – control measures – Water pollution – causes – effects – control measures.

REFERENCEBOOKS

1. Telugu Academy Intermediate chemistry Vol 1&2
2. Jain & Jain Engineering Chemistry
3. O.P. Agarwal, Hi- Tech. Engineering Chemistry
4. Sharma Engineering Chemistry
5. A.K. De Engineering Chemistry

Table specifying the scope of syllabus to be covered for unit test 1, unit test 2 and unit test 3

Unit Test	Learning outcomes to be covered
Unit Test - 1	From 1.1 to 3.7
Unit Test - 2	From 4.1 to 7.10
Unit Test - 3	From 8.1 to 11.11

Model question paper for Unit Test with Cos mapped

UNIT TEST –I

Model Question Paper (C-20)

ENGINEERING CHEMISTRY & ENVIRONMENTAL STUDIES (104)

TIME: 90 minutes

Total Marks: 40

PART-A

16 Marks

Instructions: (1) Answer all questions.

(2) First question carries 4 marks and each of rest carries 3 marks.

(3) Answers for Q.No. 2 to 5 should be brief and straight to the point and shall not exceed five simple sentences.

1. a. Number of neutrons in ${}_{11}\text{Na}^{23}$ is -----**(CO1)**
b. The molarity and normality of HCl is the same (True or False)**(CO1)**
c. What is the p^{H} range of base? **(CO1)**
d. Graphite is a good conductor of electricity (Yes or No) **(CO1)**
2. Distinguish between orbit and orbital.**(CO1)**
3. Define Covalent bond. Explain the formation of covalent bond in Oxygen and Nitrogen molecules. **(CO1)**
4. Define mole. Calculate the number of moles present in 50 gm of CaCO_3 and 9.8 gm of H_2SO_4 . **(CO1)**
5. Define P^{H} . Calculate the P^{H} of 0.001M HCl and 0.01M NaOH solution.**(CO1)**

PART – B

3x8M = 24M

Answer either (A) or (B) from each questions from Part-B.

Each question carries 8 marks.

6. A) Explain Postulations of Bhor's atomic theory. Give its limitations.**(CO1)**
(OR)
B) Explain the significance of Quantum numbers.**(CO1)**
7. A) Express molarity normality with mathematical equation. Calculate the molarity and normality of 10gm of NaOH present in 500 ml solution.**(CO1)**
(OR)
B) Classify solutions based the physical state of solute and solvent and give an example each. **(CO1)**
8. A) What is buffer solution? Classify with examples and give it's applications.**(CO1)**
(OR)
B) Explain Bronsted-Lowry theory of acids and bases. Give its limitations.**(CO1)**

UNIT TEST –II

Model Question Paper (C-20)

ENGINEERING CHEMISTRY & ENVIRONMENTAL STUDIES (104)

TIME: 90 minutes

Total Marks:40Marks

PART-A

16 Marks

Instructions: (1) Answer all questions.

(2) First question carries 4 marks and each of rest carries 3 marks.

(3) Answers for Q.No. 2 to 5 should be brief and straight to the point and shall not exceed five simple sentences.

1. a) Bauxite is the ore of metal **(CO2)**
b) What is the unit of electrochemical equivalent?**(CO2)**
c) CaSO_4 is the permanent hardness causing salt. (True or False) **(CO3)**
d) Write the Chemical formula of rust.**(CO2)**
2. Write any three differences between metallic conduction and electrolytic conduction.**(CO2)**
3. Write the composition and applications of German silver and Nichrome.**(CO1)**
4. Mention any three disadvantages of using hard water in industries.**(CO3)**
5. Define electro chemical equivalent and chemical equivalent. Give the relation between them.**(CO2)**

PART – B

3x8M = 24M

Answer either (A) or (B) from each questions from Part-B.

Each question carries 8 marks.

6. A) What is galvanic cell? Explain construction and working of galvanic cell with neat diagram **(CO2)**
(OR)
B) State and explain Faraday`s laws of electrolysis.**(CO2)**
7. A) Explain different types of galvanic cells formed during the corrosion of metals.**(CO2)**
(OR)
B) What is hard water? Explain zeolite process of softening of hard water. **(CO3)**
8. A) Explain Froth floatation process. **(CO1)**
(OR)
B) Explain Electrolytic refining processing of copper. **(CO1)**

UNIT TEST –III

Model Question Paper (C-20)

ENGINEERING CHEMISTRY & ENVIRONMENTAL STUDIES (104)

TIME: 90 minutes

Total Marks:40

PART-A

16 Marks

Instructions: (1) Answer all questions.

(2) First question carries 4 marks and each of rest carries 3 marks.

(3) Answers for Q. No. 2 to 5 should be brief and straight to the point and shall not exceed five simple sentences.

1. a) The monomer of PVC..... **(CO4)**
b) Sulphur is the vulcanising agent. (True/False) **(CO4)**
c) Give an example for secondary pollutant.**(CO5)**
d) Presence of ozone in stratosphere is a pollutant.(Yes/No)**(CO5)**
2. List any three characteristic properties of vulcanised rubber.**(CO4)**
3. Define primary fuel and secondary fuels give an example each.**(CO4)**
4. Mention the basic chemical composition and applications of vinegar.**(CO4)**
5. Write any three threats to the biodiversity.**(CO5)**

PART – B

3x8M = 24M

Answer either (A) or (B) from each questions from Part-B.

Each question carries 8 marks.

6. A) A) Explain addition and condensation polymerisation with an example each.**(CO4)**
(OR)
B) Give a method of preparation and applications of the following
i) Buna-S ii) Neoprene **(CO4)**
7. A) What is air pollution? Explain any three causes of air pollution.**(CO5)**
(OR)
B) Briefly explain ozone layer depletion and green house effect.**(CO5)**
8. A) What is water pollution? Explain any three controlling methods of water pollution.**(CO5)**
(OR)
B) What are thermoplastics and thermo setting plastic? Write any four differences between these two plastics. **(CO4)**

Model Question Paper (C-20)

ENGINEERING CHEMISTRY & ENVIRONMENTAL STUDIES (104)

TIME: 3hrs

Total Marks:80

PART-A

Instructions: (1) Answer all questions.

(2) Each question carries 3 marks.

Answer all questions. Each question carries three marks. 3x10=30M

1. Draw the shapes of s and p orbitals. (CO1)
2. Define mole. Find the mole number of 10 g of CaCO_3 (CO1)
3. Define Buffer solution. Give any two examples. (CO1)
4. Define chemical equivalent and electrochemical equivalent. Give their relation. (CO2)
5. State name of the salts and their formulae that cause hardness. (CO3)
6. Write any three disadvantages of using plastics. (CO4)
7. Classify the fuels based on their occurrence. (CO4)
8. Mention the basic chemical composition and applications of vinegar. (CO4)
9. List out any three threats to biodiversity. (CO5)
10. Define pollutant and contaminant. Give an example each. (CO5)

PART – B

Each question carries eight marks.

8x5=40M

11. A) Explain Bohr's atomic theory and give its limitations. (CO1)
(OR)
B) Explain ionic bond formation and covalent bond formation with one example each (CO1)
12. A) Calculate the molarity and normality of 250 ml of sodium carbonate solution that contains 10.6 gm of sodium carbonate. (CO1)
(OR)
B) Explain Bronstead and Lowry theory of acids and bases. Give its limitations. (CO1)
13. A) Explain froth floatation and electrolytic refining of copper with neat diagrams.(CO1)
(OR)
B) Explain the construction and working of galvanic cell. (CO2)
14. A) Explain Cathode protection methods. (CO2)
(OR)
B) Explain ion-exchange of softening of hard water with a neat diagram. (CO3)
15. A) Explain addition and condensation polymerisation with an example each.(CO4)
(OR)
B) Explain the causes and effects of air pollution.(CO5)

PART –C

Question carries ten marks

10x1 =10M

16. Analyse the products formed at cathode and anode with electrode reactions during the Electrolysis of aqueous NaCl in compare with fused NaCl. **(CO2)**

ENGINEERING MECHANICS

Course Code	Course Title	No. of Periods per Week	Total No. of Periods	Marks for Formative Assessment	Marks for Summative Assessment
C-105	ENGINEERING MECHANICS	05	150	20	80

S.No.	Chapter/Unit Title	No. of Periods	COs Mapped
1	Introduction	4	CO1
2	Forces & Moments	18	CO1
3	Centroid	18	CO2
4	Moment of Inertia	30	CO2
5	Simple Stresses and Strains	40	CO3
6	Shear force and Bending Moment	40	CO4
	Total	150	

COURSE OBJECTIVES:

Upon completion of the course the student shall be able to

Course Objectives	(i)	Familiarize with the concepts of forces and their types, applications of forces and moments, calculate the geometric properties like Centroid and moment of inertia... etc., for various sections
	(ii)	Acquire the concepts of simple stresses and strains and their applications, and their relevance to mechanical properties of metals
	(iii)	Understand the effect of loading on beams, analyses Shear Force and Bending Moment of simple beams

COURSE OUTCOMES:

Course Outcomes	CO 1	C 105.1	Explain the basic concepts of Engineering Mechanics and concept of different forces & moments and applying these principles for Civil Engineering problems.
	CO 2	C 105.2	Compute the Centroid, Centre of gravity, Moment of Inertia and Radius of gyration for various sections
	CO 3	C 105.3	Calculate the simple Stresses and Strains in structural materials
	CO4	C 105.4	Explain concepts of shear force and bending moments, Compute the SF, BM values and Draws the SFD and BMD for beams.

LEARNING OUTCOMES:

Learning Outcomes	<p>1.0 Introduction</p> <ul style="list-style-type: none">1.1 Define Mechanics and Engineering Mechanics1.2 State the applications of Engineering Mechanics1.3 State the branches of Engineering Mechanics1.3 Define the terms 1.Statics, 2.Dynamics, 3.Kinetics and 4.Kinematics1.4 List the systems of measurements and Units1.5 List S.I and M.K.S units of physical quantities used in Civil Engineering <p>2.0 Forces and Moments</p> <p>2.1 Define the following terms:</p> <ul style="list-style-type: none">1. Force2. Moment3. Resultant4. Equilibrium of forces5. Equilibrant6. Moment of a couple <p>2.2 Distinguish between</p> <ul style="list-style-type: none">2.2.1 Scalar and Vector quantities2.2.2 Co-planar and non-co-planar forces2.2.3 Parallel and non-parallel forces2.2.4 Like and unlike parallel forces <p>2.3 Compute the resultant of two co-planar forces acting at a point by</p> <ul style="list-style-type: none">2.3.1 Law of parallelogram of forces and2.3.2 Triangle law of forces <p>2.4 Explain 'Lami's Theorem' and 'Polygon Law of forces'</p> <ul style="list-style-type: none">2.41 Solve simple problems using Lami's Theorem <p>2.5 Explain 'Polygon Law of forces'</p> <ul style="list-style-type: none">2.5.1 Compute the resultant of a system of coplanar concurrent forces by Polygon Law of forces2.5.2 Define 'Resolution of forces' <p>2.6. Solve problems on computation of the resultant of a system of coplanar parallel forces.</p> <p>2.7. Explain the properties of a couple.</p> <p>2.8. List the conditions of equilibrium of rigid body subjected to a number of co- planar forces.</p> <ul style="list-style-type: none">2.8.1. Calculate resultant of co-planar concurrent forcesby analytical methods. <p>2.9 List various types of supports like Simple support, fixed support, hinged support, roller support, List various types of beams like simply supportedbeams, cantileverbeams, fixed beams, over hanging beams, continuous beams.</p> <p>2.10 List various types of loads like point load, uniformly distributed load, uniformly varying load ,Calculate the support reactions for simply supported beams with point loads and Uniformly distributedloading</p> <p>3.0 Centroid</p> <ul style="list-style-type: none">3.1 Define Centroid and Centre of gravity3.2 Distinguish between Centroid and Centre of gravity
--------------------------	---

	<p>3.3 State the need for finding the Centroid and Centre of gravity for various engineering applications.</p> <p>3.4 Calculate the positions of Centroid for simple plane figures from first principles</p> <p>3.5 Explain the method of determining the Centroid by 'Method of moments'.</p> <p>3.6 Calculate the position of Centroid of standard Sections-T, L, I, Channel section, Z section, unsymmetrical I section</p> <p>3.7 Calculate the position of Centroid of built up sections consisting of RSJ's and flange plates and Plane figures having hollow portions</p> <p>4.0. Moment of Inertia</p> <p>4.1 Define Moment of Inertia, Polar Moment of Inertia and Radius of gyration</p> <p>4.2 State the necessity of finding Moment of Inertia for various engineering applications</p> <p>4.3 Compute Moment of Inertia and Radius of gyration for regular geometrical sections like T, L, I, Channel section, Z section and unsymmetrical I section</p> <p>4.4 State 1. Parallel axes theorem and 2. Perpendicular axes theorem to determine Moment of Inertia</p> <p>4.5 Compute MI of standard sections by applying parallel axis theorem.</p> <p>4.6 Compute MI of built-up sections by applying parallel axis theorem.</p> <p>4.7 Calculate radius of gyration of standard sections.</p> <p>4.8 Compute Polar Moment of Inertia for solid and hollow circular Section by applying perpendicular axes theorem.</p> <p>5.0. Simple Stresses and Strains</p> <p>5.1 Define the following terms:</p> <ol style="list-style-type: none"> 1. Stress 2. Strain 3. Modulus of Elasticity 4. Longitudinal Strain 5. Lateral Strain 6. Poisson's ratio 7. Modulus of rigidity 8. Bulk Modulus 9. working stress, 10. Factor of safety 11. Resilience 12. Strain Energy 13. Proof resilience 14. Modulus of Resilience <p>5.2 Distinguish between different kinds of stresses and strains.</p> <p>5.3 Draw the stress-strain curve for ductile materials (Mild steel) and Hence explain the salient points on the curve.</p> <p>5.4 State Hooke's law and limits of proportionality, State the factors affecting factor of safety</p> <p>5.5 Solve problems on relationship between simple stress and simple strain under axial loading on uniform bars and stepped bars.</p>
--	--

	<p>5.6 State the relationship among the elastic constants, Solve problems on relationship between elastic constants.</p> <p>5.7 Calculate stresses in simple and composite members under axial loading</p> <p>5.8 Define temperature stress, strain, hoops stress, Explain the concept of temperature stresses in composite sections.</p> <p>5.9 Calculate instantaneous stress and strain Energy due to dynamic loads and impact loading.</p> <p>5.10 List and explain mechanical properties of materials</p> <p>6.0 Shear force and Bending moment</p> <p>6.1 Define</p> <ol style="list-style-type: none"> a) Cantilever beam b) Simply supported beam c) Fixed beam d) Continuous beam e) Overhanging beam <p>Define</p> <ol style="list-style-type: none"> a) Point Load b) Uniformly Distributed Load <p>Describe</p> <ol style="list-style-type: none"> a) Roller support b) Hinged support c) Fixed support <p>6.2 Calculate reactions at rollers/hinged and fixed supports for</p> <ol style="list-style-type: none"> 1. Simply Supported beams, 2. Cantilever beams and 3. Overhanging beams. <p>6.3 Explain a) Shear Force and b) Bending Moment</p> <p>6.4 Explain sign conventions used for drawing 1. Shear Force and 2. Bending Moment</p> <p>6.5 Deduce the relationship among the rate of loading, shear force and bending moment</p> <p>6.6 Determine Shear Force and Bending Moments on Cantilever and Simply Supported beams for simple cases of loading (Point Load, Uniformly Distributed Load) analytically</p> <p>6.7 Describe the procedures for sketching the Shear Force Diagrams (SFD) and Bending Moment Diagrams (BMD)</p> <p>6.8 Sketch Shear Force Diagrams (SFD) and Bending Moment Diagrams (BMD) for Cantilever and Simply Supported Beams</p> <p>6.9 Define point of contra flexure</p> <p>6.10 Determine the Shear Force, Bending Moment and point of contra flexure for overhanging beams and sketch Shear Force Diagrams (SFD) and Bending Moment Diagrams (BMD) for overhanging beams</p>
--	---

PO-CO MAPPING:

C-105	ENGINEERING MECHANICS No. of COs: 04				No. of Periods: 150
POs	Mapped with CO Nos.	CO periods addressing PO in Col.1		Level (1,2,3)	Remarks
		No.	%		
1	CO1, CO2, CO3, CO4	55	37	2	>40% Level.3 (Highly addressed) 25% - 40% Level.2 (Moderately addressed) 5% - 25% Level.1 (Low addressed) <5% Not addressed
2	CO1, CO2, CO3, CO4	65	43	3	
3	CO1, CO2, CO3, CO4	20	13	1	
4	CO2	10	07	1	
5					
6					
7					

CO-PO MAPPING:

CO No.	PO1	PO2	PO3	PO4	PO5	PO6	PO7	PSO1	PSO2	PSO3
CO1	2	2	2					2	3	1
CO2	2	2	2	1				2	3	1
CO3	3	3	3					2	3	1
CO4	3	3	2					2	3	1
Average	2.5	2.5	2.25	1				2	3	1

Note : The gaps in CO-PO mapping will be met by one or more appropriate activities from the following:

- (i) Assignments (ii) Tutorials (iii) Seminars (iv) Guest lectures (v) Group discussions (vi) Quiz (vii) Industrial visits (viii) Tech fests (ix) Mini project works (x) Library visits etc

COURSE CONTENT:**1. Introduction**

Mechanics-Engineering Mechanics-Applications and branches of Engineering Mechanics - Statics, Dynamics, Kinetics and Kinematics - Systems of measurements and Units - S.I and M.K.S units of physical quantities used in Civil Engineering

2. Forces & Moments

Definition of force - Vectors and Scalars - Vector representation of a force - systems of forces - Co-planar forces - Resultant of forces at a point – Parallelogram Law and Triangle Law of forces – Lami's theorem – Polygon law of forces – Resolution of forces- Parallel forces – like and unlike forces – moment of a force - units and sense-couple-moment of a couple – properties of a couple - Conditions of equilibrium of a rigid body subjected to a number of co-planar forces - Structural members supporting co-planar forces - Types of supports- Types of beams - Types of loading- Determination of support reactions for simply supported beams with point loads and Uniformly distributed loading.

3. Centroid

Definitions – Centroid - Centre of gravity - Position of Centroid of standard figures like rectangle, triangle, parallelogram circle, semi-circle and trapezium - Determination of location of Centroid of standard sections - T, L, I, Channel section, Z section and built up sections consisting of RSJs and flange plates and plane figures having hollow portion.

4. Moment of Inertia

Definition of Moment of Inertia - Perpendicular and parallel axes theorems – Moment of Inertia of standard sections like rectangle, triangle, circle and hollow circular sections - Moment of Inertia of built up sections- T, L, I, Channel section and Z sections using parallel axis theorem - Moment of Inertia and radius of gyration of built-up sections consisting of the combinations of RSJ's flange plates, channels & flange plates etc - Polar Moment of Inertia of solid and hollow circular sections using Perpendicular axis theorem

5. Simple Stresses and Strains

Stress and strain – type of stresses and strains - Stress strain curves for ductile materials- mild steel, elastic limit, limit of proportionality, yield point, ultimate stress; breaking stress; working stress, factor of safety – Factors affecting factor of safety - Hooke's law – Young's modulus – deformation under axial load - Shear stress and Shear Strain – Modulus of rigidity - Longitudinal and lateral strain - Poisson's ratio - Bulk Modulus – relationship between elastic constants (Proof not required, only problems) - Composite sections – Effect of axial loads - Temperature stresses – strains – Hoop stress - Temperature stresses in composite sections - Resilience – strain energy-proof resilience and modulus of resilience – maximum instantaneous stress due to gradual, sudden and shock loading - Mechanical properties of materials-elasticity, plasticity, ductility, brittleness, malleability, stiffness, hardness, toughness, creep, fatigue, examples of materials which exhibit the above properties.

6.0 Shear force and bending Moment

Beams – Types of beams – Cantilevers – Simply supported – Overhanging – Fixed and continuous -Types of supports – Roller – Hinged – Fixed - explanation of S.F and B.M. at a section- Relation between rate of loading SF and BM - Calculation of S.F. and B.M values at different sections for cantilevers Simply supported beams - overhanging beams under point loads and uniformly distributed loads, position and significance of points of contra flexure - Drawing S.F. and B.M diagrams by analytical methods – location of points of contra flexure.

REFERENCE BOOKS:

- | | | | |
|----|--------------------|---|--|
| 1. | N. H. Dubey | : | Engineering Mechanics (Tata McGraw Hill) |
| 2. | R.S. Kurmi | : | Engineering Mechanics |
| 3. | P.K. Abdul Latheef | : | Engineering Mechanics |
| 4. | Dayaratnam | : | Engineering Mechanics & Statics |
| 5. | N. Srinivasulu | : | Engineering Mechanics |

MODEL BLUE PRINT

S. No	Chapter Title	No. of periods	Weightage Allocated	Marks wise Distribution of Weightage				Question wise Distribution of Weightage				Linked with CO
				R	U	Ap	An	R	U	Ap	An	
1.	Introduction	4	03	03	--	--	--	1	-	-	--	CO1
2.	Forces & Moments	18	14	03	03	08	--	1	1	1	--	CO1
3.	Centroid	18	11	03	--	08	--	1	--	1	--	CO2
4.	Moment of Inertia	30	11	03	--	08	--	1	--	1	--	CO2
5.	Simple Stresses and Strains	40	17	03	06	08	--	1	2	1	--	CO3
6	Shear force and Bending moment	40	14	03	03	08	---	1	1	1	--	CO4
	Higher order question from any or combination of 5 & 6 Chapters	--	10	--	--	--	10	--	--	--	1	CO3 & CO 4
	Total	150	80	18	12	40	10	6	4	5	1	

Table specifying the scope of syllabus to be covered for Unit Test-I, Unit Test-II & Unit Test -III

Unit Test	Learning outcomes to be covered
Unit Test-I	From 1.1 to 3.7
Unit Test-II	From 4.1 to 5.5
Unit Test -III	From 5.6 to 6.10

Model Paper for Unit Test-I:

**State Board of Technical Education and Training, A.P.
Diploma in Civil Engineering (DCE)
Third Semester: C-105 ENGINEERING MECHANICS**

Time: 90 Minutes

Unit Test –I

Maximum Marks: 40

PART- A

16 Marks

Instructions:

- (i) Answer all questions
- (ii) First question carries FOUR marks, each question of remaining carries THREE marks.

- 1.(a) _____ & Dynamics are the branches of Engineering Mechanics (CO1)
- (b)The forces, which are lying in the same plane, are called as _____ forces (CO1)
- (c)The centroid of a semi circle with radius 'r' lies at a distance of _____ from the base (CO2)
- (d) The cycle pedal is the example for a Collinear force (True/False) (CO1)
2. State the (i) Parallelogram law of forces (ii) Lami's Theorem
3. Two forces act at an angle of 120° . The bigger force is 60 kN and the resultant is perpendicular to the smaller one. Find the smaller force. (CO1)
4. State the need for finding the centroid and centre of gravity for various engineering Applications (CO2).
5. Determine the centre of gravity of the remaining portion of a circular sheet metal of radius 50 mm, when a hole of 25 mm radius of circle is cut from the right side horizontal axis of the 50 mm radius circle (CO2)

PART- B

3 x 8 = 24 Marks

Instructions:

- (i) Answer all questions
- (ii) Each question carries EIGHT marks
- (iii) Answer should be comprehensive and the criterion for valuation is the content but not the length of the answer.

6. (A) Find the magnitude and direction of resultant force for following forces acting at a point
 - (a) 30 KN due S
 - (b) 25 KN due N-E
 - (c) 62 KN due W
 - (d) 80 KN at 60° E of S and
 - (e) 70 KN at 40° S of W (CO1)

(OR)

- (B) Four forces acting at a point are in equilibrium. Three of them are: 200N due S, 400N due N-E, and 500N at 30° east of south. Find analytically the magnitude and direction of the Fourth force. (CO1)

7. (A) A body of weight 1000 N is suspended by two strings of 4 meters and 3 meters lengths attached at the same horizontal level 5 meters apart. Calculate the forces in the strings. (CO1)

(OR)

- (B) Five forces 20N, 30N, 40N, 50N and 60N are acting on one of the angular points of a regular hexagon towards the other five angular point taken in order. Find the magnitude and direction of the resultant force. (CO1)

8. (A) A masonry dam is trapezoidal in section with one face vertical. The top width is a m, bottom width is b m and the height is h m. Find the position of centroid from the vertical face of the dam. (CO2)

(OR)

(B) Find the C.G. of an I-section with top flange $100\text{mm} \times 20\text{mm}$, web $30\text{mm} \times 200\text{mm}$ and bottom flange $300\text{mm} \times 40\text{mm}$ (CO2)

Model Paper for Unit Test-II:

**State Board of Technical Education and Training, A.P.
Diploma in Civil Engineering (DCE)
Third Semester: C-105 ENGINEERING MECHANICS**

Time: 90 Minutes

Unit Test –II

Maximum Marks: 40

PART- A

16 Marks

Instructions:

- (i) Answer all questions
- (ii) First question carries FOUR marks, each question of remaining carries THREE marks.

1. (a) The second moment of an area is called _____ (CO2)
- (b) The formula for moment of inertia of a triangle about its base is _____ (CO2)
- (c) The stress is directly proportional to the strain within _____ limit (CO3)
- (d) The ratio between linear strain and lateral strain is called _____ (CO3)
2. The moment of inertia of a square about its base is 900 mm^4 . Find the values of I_{xx} , I_{yy} and I_{zz} for the square. (CO2)
3. Define the terms Young's Modulus and Shear modulus (CO3)
4. Draw Stress-Strain Curve for Mild Steel specimen and indicate salient points (CO3)
5. Write any three relationships among elastic constants. (CO3)

PART- B

3 x 8 = 24 Marks

Instructions:

- (i) Answer all questions
- (ii) Each question carries EIGHT marks
- (iii) Answer should be comprehensive and the criterion for valuation is the content but not the length of the answer.

- 6.(A) Find the Moment of Inertia of an angular section $350 \times 250 \times 16 \text{ mm}$ with its long leg vertical. (CO2)

(OR)

- (B) Determine the moment of inertia about the centroidal axes for a built - up section having four equal angle sections forming a box of size 180 mm . The single angle section is $90 \text{ mm} \times 90 \text{ mm} \times 10 \text{ mm}$. The properties of angle section $A = 1047 \text{ mm}^2$; $I_{xx} = I_{yy} = 8.1 \times 10^5 \text{ mm}^4$, $C_{xx} = C_{yy} = 24.2 \text{ mm}$ (CO2)

- 7.(A) A steel flat of 400 mm length, 80 mm width and 15 mm thickness is subjected to an axial compression of 150 KN . The young's modulus of steel is $2 \times 10^5 \text{ N/mm}^2$ and Poisson's ratio is 0.3 . Determine change in length, width and volume of flat. (CO3)

(OR)

- (B) A round bar 400 mm^2 in cross sectional area and 100 mm in length is subjected to an axial thrust of 80 kN . If the length of the bar is decreased by 0.17 mm and its diameter increases by 0.01 mm . Determine the Poisson's ratio and three elastic moduli for the material of the bar.

(CO3)

8. (A) Two channels ISLC 400 are to be placed back to back so that I_{xx} and I_{yy} of sections are equal. Determine the clear distance between back of the channels. For each channels $I_{xx} = 1.4 \times 10^8 \text{ mm}^4$, $I_{yy} = 4.6 \times 10^6 \text{ mm}^4$, $A = 5800 \text{ mm}^2$, $C_{yy} = 30 \text{ mm}$. (CO3)

(OR)

- (B) A bar of 25 mm diameter and 600 mm long is subjected to a pull of 50 kN. The change in diameter and length was observed to be 0.03 mm and 0.30 mm. Calculate (a) Young's modulus, (b) Poisson's ratio, (c) Modulus of rigidity and (d) Factor of safety if ultimate stress = 204 N/mm^2 . (CO3)

Model Paper for Unit Test-III:

**State Board of Technical Education and Training, A.P.
Diploma in Civil Engineering (DCE)
Third Semester: C-105 ENGINEERING MECHANICS**

Time: 90 Minutes

Unit Test –III

Maximum Marks: 40

PART- A

16 Marks

Instructions:

- (i) Answer all questions
- (ii) First question carries FOUR marks, each question of remaining carries THREE marks.

- 1.(i) The bending moment at the point of contra flexure is _____ (CO4)
- (ii) What is the bending moment at end supports of a simply supported beam?
 - a) Maximum
 - b) Minimum
 - c) Zero
 - d) Uniform (CO4)
- (iii) How do point loads and udl be represented in SFD?
 - a) Simple lines and curved lines
 - b) Curved lines and inclined lines
 - c) Simple lines and inclined lines
 - d) Cant represent any more (CO4)
- (iv) The parallel axis theorem gives the moment of inertia _____ to the surface of consideration.
 - a) Linear
 - b) Non-Linear
 - c) Perpendicular
 - d) Parallel (CO3)
2. A wooden wheel of 2000 mm diameter is to be fitted with a steel ring of 1990 mm internal diameter. Determine (a) Stress developed in steel and (b) Minimum temperature required to fit the steel ring over wooden wheel. Take Young's modulus of steel as $2 \times 10^5 \text{ N/mm}^2$ and Co-efficient of thermal expansion as $12 \times 10^{-6}/^\circ\text{C}$ (CO3)
3. Write the relationship between rate of loading, shear force and bending moment. (CO4)
4. A simple supported beam of span 6 m carries a uniformly distributed load of 10 kN/m over the left hand half of the span and a concentrated load of 20 kN at a distance of 1 m from the right hand support. Find the reaction at the supports. (CO4)
5. A cantilever 4 meters long carries a uniformly distributed load of 8 kN/m over a length of 2.5 m from free end. Draw the shear force and bending moment diagrams for the above loading system.. (CO4)

PART- B

3 x 8 = 24 Marks

Instructions:

- (i) Answer all questions
- (ii) Each question carries EIGHT marks
- (iii) Answer should be comprehensive and the criterion for valuation is the content but not the length of the answer.

6.(A) A load of 80 kN is suddenly applied on a bar 4 m long and 1000 mm^2 in cross-section. Calculate the maximum instantaneous stress produced and strain energy stored in the bar if $E = 200 \text{ GPa}$.

(CO3)

(OR)

(B) An RCC column $500 \text{ mm} \times 450 \text{ mm}$ in section is provided with 6 nos. of 40 mm diameter bars. The column carries an axial load of 600 kN. Find the stresses in concrete and steel and also calculate the loads shared by concrete and steel if $m = 15$.

(CO3)

7.(A) A cantilever of length 4 m carries a point load of 5 kN at its free end and a u.d.l. of 2 kN/m over a length of 2 m from the fixed end. Draw the SF and BM diagrams indicating their maximum values.

(CO4)

(OR)

(B) A uniform beam of 8 m length is supported at its left hand end and at 2 m from its right hand end. Three point loads of 180 kN, 50 kN and 30 kN are carried by the beam at 2 m, 4 m and 8 m from its left support respectively. Draw SF and BM diagrams and show the values at salient points.

(CO4)

8. (A) A simply supported beam of span 8 meters carries a uniformly distributed load of 20 kN/m in the right half of the beam and a concentrated load of 40 kN at a distance of 2 m from left support. Draw the shear force and bending moment diagram. Also show the maximum bending moment .

(CO4)

(OR)

(B) A beam of length 12 m is supported by two supports at 2 m from left end and another at 2 m from right end. It carries a uniformly distributed load of 10 kN/m over its 12 m length. It is also loaded with a point load of 20 kN placed at 5 meters from left support and another point load of 4 kN placed at right face end. Draw the shear force diagram and bending moment diagram. Also determine the position and magnitudes of maximum hogging and sagging moments

(CO4)

oOo

Model Paper for End Examination:

**MODEL PAPER – BOARD DIPLOMA EXAMINATION, (C–20)
DCE—FIRST YEAR EXAMINATION
ENGINEERING MECHANICS (C-105)**

Time: 3 hours]

[Total Marks: 80

PART—A

3×10=30 Marks

- Instructions:**(1) Answer **all** questions.
(2) Each question carries **three** marks.
(3) Answers should be brief and straight to the point and shall not exceed *five* simple sentence

- 1) Define the terms 1.Statics 2.Dynamics. (CO1)
- 2) State Parallelogram and triangle law of forces (CO1)
- 3) State the characteristics of couple. (CO1)
- 4) Distinguish between centriod and centre of gravity (CO2)
- 5) State and explain Parallel axis theorem (CO2)
- 6) Define the terms Young’s Modulus and Modulus of Rigidity (CO3)
- 7) Draw Stress-Strain Curve for Mild Steel specimen and indicate salient points (CO3)
- 8) State elastic constants and write their relationship. (CO3)
- 9) Define the terms Shear Force and Bending Moment.(CO4)
- 10) Obtain the expressions for maximum SF and BM for SS beam carrying UDL through its length. (CO4)

PART – B

8 x 5 = 40 marks

Answer either (a) **or** (b) from each questions from Part-B

- 11) (A) Find the magnitude and direction of resultant force for following forces acting at a point
- (a) 80 KN due N
 - (b) 20 KN due N-E
 - (c) 40 KN due E
 - (d) 60 KN at 60° E of S and
 - (e) 70 KN at 60° S of W (CO1)

(OR)

- (B) Four forces acting at a point are in equilibrium. Three of them are: 200N due S, 400N due N-E, and 500N at 30° east of south. Find analytically the magnitude and direction of the fourth force.

(CO1)

- 12) (A) Find the C.G. of an I-section with top flange 100mmX20mm, web 30mmX200 mm and bottom flange 300mmX40mm (CO2)

(OR)

- (B) Locate the centre of gravity of given Z – section with reference to the axes OX and OY. (CO2)

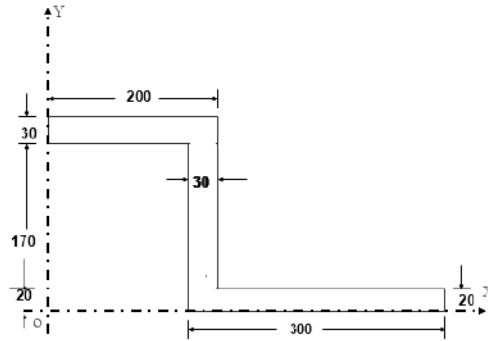

- 13) (A) Two ISLC250 back at a clear

back at a clear distance of 100 mm. Flange plates are attached at top and bottom. Each plate is 300 x 30 mm. For each channel section, Area = 3000 mm², Flange width = 100mm, I_{XX} = 25.5 x 10⁶ mm⁴, I_{YY} = 2.1 x 10⁶ mm⁴, Distance of centroid from back of web = 25 mm, Determine moment of inertia about centroidal axes. (CO2)

(OR)

- (B) Find the Moment of Inertia of an angular section 350 x 250 x 16 mm with its long leg vertical. (CO2)

- 14) (A) A steel flat of 500mm length, 60mm width and 20mm thickness is subjected to an axial compression of 168 kN. The young's modulus of steel is 2 x 10⁵ N/mm² and Poisson's ratio is 0.3. Determine change in length, width and volume of flat. (CO3)

(OR)

- (B) A steel bar 1.6 m long is acted upon by forces as shown in figure. Find the elongation of the bar. Given E = 200 G Pa. (CO3)

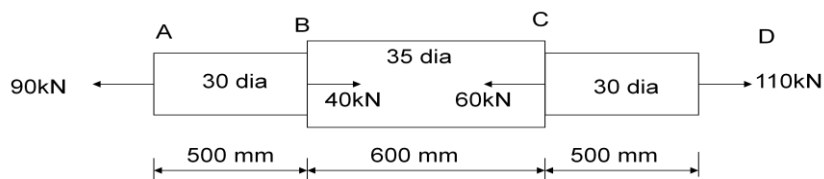

- 15) (A) A cantilever 5m long carries three point loads of 20 kN, 30 kN at 1m, 2.5m and 4m respectively from free end. Draw S.F and B.M diagrams. Calculate S.F and B.M at 4.5 m from free end. (CO4)

(OR)

- (B) A beam of span 8m freely supported at its ends carries a UDL of 10kN/m over a length of 3m from the left hand support. It also carries another UDL of 15kN/m over a length of 2m from the right hand support in addition to a point load of 30kN at its mid span. Calculate the Maximum SF and BM and draw SFD and BMD. (CO4)

PART – C

Question **No.16** is compulsory and carries **10 marks**

10 x1 = 10 marks

16) Determine the Shear Force and Bending Moment at salient locations of the overhanging beam shown in the figure and sketch the SFD & BMD. State the values of Maximum S.F. and B.M. Locate the Points of Contraflexure. (CO5)

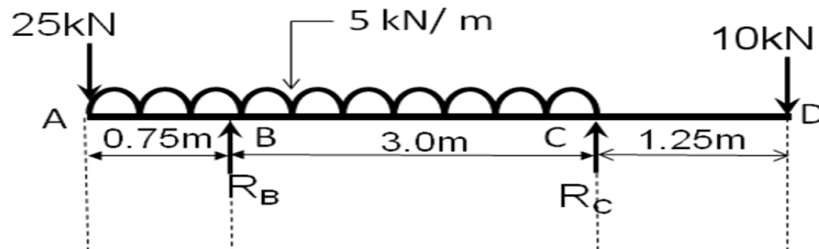

Course Code	Course Title	No. of Periods per Week	Total No. of Periods	Marks for Formative Assessment	Marks for Summative Assessment
C-106	SURVEYING-I	03	90	20	80

S. No.	Major Topics	No. of Periods	COs Mapped
1.	Introduction to Surveying	5	CO1
2.	Chain Surveying	21	CO2
3.	Compass Surveying	21	CO3
4.	Levelling	40	CO4
5.	Minor Instruments	03	CO5
	Total	90	

COURSE OBJECTIVES:

Upon completion of the course the student shall be able to		
Course Objectives	(i)	Acquire basic knowledge about principles of surveying for location, design and construction of engineering projects.
	(ii)	Develop skills in using basic surveying instruments like measuring chains, tapes, compass, levels & minor instruments

COURSE OUTCOMES:

Course Outcomes	CO1	C-106.1	State the fundamental principles of Surveying.
	CO2	C-106.2	Explain the principle of chain surveying and Perform the operations involved in chaining on flat and sloping grounds and when high ground intervenes, Practice chain triangulation/traversing for location survey.
	CO3	C-106.3	Describe the operations involved in field compass surveying like taking bearings and calculation of included angles & traversing.
	CO4	C-106.4	Explain the fundamental principles of levelling, tabulate the levelling field data, explain computation of reduced levels, different types of levelling, errors involved in levelling and contours.
	CO5	C-106.5	List the various minor instruments used in surveying and their uses.

LEARNING OUTCOMES:

Learning Outcomes	<p>1. Introduction to surveying</p> <ul style="list-style-type: none">1.1 State the concept of surveying.1.2 State the purpose of surveying.1.3 Distinguish between 1. Plane and 2. Geodetic surveying.1.4 State the units of linear and angular measurements in Surveying and conversions.1.5 List the instruments used for taking linear and angular measurements.1.6 Classify different types of surveys.1.7 State the fundamental principles of surveying.1.8 State and explain different stages of survey operations. <p>2.0 Chain Surveying</p> <ul style="list-style-type: none">2.1 State the purpose and principle of Chain surveying and explain the principles used in Chain triangulation.2.2 List different instruments used in Chain Surveying and explain their functions.2.3 List the six points to be followed while selecting the survey stations2.4 Define ranging and explain methods of ranging a line.2.5 List the all operations involved in chaining on 1. Flat ground 2. Sloping ground and 3. When high ground intervenes.2.6 Describe in detail the method of setting out right angles, explain Field work procedure in Chain survey and Method of recording field observations2.7 List the errors and mistakes in Chain surveying and apply the corrections for measurement due to incorrect length of chain2.8 Explain the methods of overcoming different obstacles in chain surveying.2.9 Explain the methods of preparing site plans by Chain Surveying.2.10 Calculate the areas of irregular boundaries using Average Ordinate rule, Trapezoidal rule and Simpson's rule. <p>3.0 Compass Surveying</p> <ul style="list-style-type: none">3.1 State the purpose and principles of Compass surveying.3.2 Identify the parts of Prismatic Compass and state their functions3.3 Define -Whole Circle Bearing, Quadrantal Bearing, True meridian, Magnetic meridian, True bearing, Magnetic bearing, Dip, Declination and Local attraction.3.4 Convert Whole Circle Bearing in to Quadrantal Bearing and vice versa.3.5 Explain local attraction and its effects.3.6 Compute the included angles of lines in a Compass traverse and the true bearings of lines in a Compass traverse.3.7 Explain the operations involved in field in compass Surveying.3.8 Explain methods of recording field notes and plotting Compass Surveying.
--------------------------	---

3.9 Explain the method of plotting closed traverse adjusting closing error by Bowditch rule.

3.10 Explain errors in Compass surveying.

4.0 Levelling

4.1 Define levelling and List the types of levelling instruments, Define the terms -Datum or Datum plane, Reduced level, Level surface, Horizontal surface, Vertical Line and Station, Mean sea level ,Bench Mark

4.2 List the component parts of a dumpy level and their functions, explain the steps involved in temporary adjustments of a dumpy level, Define Back sight, Fore sight, Intermediate sight, Change Point.

4.3 List different types of levelling staves, tabulate the levelling field data, state methods of reducing levels, Compare height of instrument and Rise and fall methods, Compute reduced levels by height of instrument and Rise and fall methods, and apply check.

4.4 List the different types of Levelling, Describe in detail Profile levelling and Reciprocal levelling

4.5 State the Errors in levelling and the Precautions to be taken to prevent errors in levelling, Explain the effect of Errors due to Curvature and Refraction, Compute the error due to Curvature, Refraction and Combined error and apply correction to be applied for the above errors

4.6 List the errors eliminated in reciprocal levelling, Derive the formula for true difference in elevation and true error between two points, Calculate true difference in elevation and collimation error in reciprocal levelling

4.7 List the fundamental lines of dumpy level and state the relationship among fundamental lines of dumpy level

4.8 Explain permanent adjustments of a dumpy level (Two peg method without problems)

4.9 Define Contour, Contour interval and Horizontal equivalent, List the Characteristics and uses of contours, explain different methods of contouring and interpolation of contours

4.10 Explain the method of tracing contour gradient / alignment of hill road

5.0 Minor Instruments

5.1 Explain the need for using Minor instruments

5.2 List various minor instruments used in surveying

5.3 Explain the uses of the following minor instruments:

1. Abney Level, 2. Pentagraph and 3. Electronic Planimeter

PO-CO Mapping:

Course Code : C-106	Course Title: Surveying – I Number of COs: 05			No. of Periods: 90	
POs	Mapped with CO Nos	CO Periods addressing PO in Col. 1		Level (1,2,3)	Remarks
		No	%		
PO1	CO1, CO2, CO3, CO4, CO5	42	47	3	> 40% Level 3 Highly addressed 25% to 40% Level 2 Moderately addressed 5 to 25% Level 1 Low addressed
PO2	CO2,CO3,CO4	31	34	2	
PO3					
PO4	CO2, CO4	12	13	1	
PO5	CO2	5	6	1	
PO6					
PO7					

CO-PO Mapping:

CO No.	PO1	PO2	PO3	PO4	PO5	PO6	PO7	PSO1	PSO2	PSO3
CO1	2							2	3	2
CO2	2	2		2	2			2	3	2
CO3	3	3						2	3	2
CO4	3	3		2				2	3	2
CO5	3							2	3	2
Average	2.6	2.67		2	2			2	3	2

Note : The gaps in CO-PO mapping will be met by one or more appropriate activities from the following:

- (i) Assignments (ii) Tutorials (iii) Seminars (iv) Guest lectures (v) Group discussions (vi) Quiz (vii) Industrial visits (viii) Tech fests (ix) Mini project works (x) Library visits etc**

COURSE CONTENT:

1.0 Classification and Principles of Surveying

Definition-Concept of Surveying-purpose of Surveying-Divisions of surveying- Classification of Surveying based on different criteria- Fundamental principles in Surveying -Measurements- Units and conversions-Instruments used for taking linear and angular measurements- Stages of survey operations-Field work, Office work, Care and adjustments of the instruments.

2.0 Chain Surveying

Purpose and Principle of Chain Surveying -Suitability of Chain Surveying-Survey stations and their selection-Survey lines and offsets – Instruments used in Chain survey and their function

Ranging a survey line- direct ranging and Indirect ranging –Chaining a line –Duties of leader and follower- Chaining on a sloping ground-Errors and mistakes in ordinary chaining –Correction due to incorrect length of Chain- problems –Different operations in Chain Surveying- Setting out right angles with cross staff and Optical square- Cross staff survey Field work procedure- Recording field notes – field book -Conventional signs - Obstacles in chain survey -methods to overcome obstacles-Problems Calculations of area – different methods –Average ordinate, Trapezoidal and Simpson's rules.

3.0 Compass Surveying

Introduction, Purpose, principle and uses of compass Survey- Traverse-Open and Closed Traverse – Theory of magnetism-Description working and use of Prismatic compass-Operations in using Compass before taking readings - Concept of Meridian-Types of meridians-Bearing and angle-Designation of bearings- Whole Circle Bearing. Quadrantal Bearing Conversions-Field work in Compass Survey –field notes-traverse using prismatic compass -Local attraction-detection and correction, Dip and Magnetic declination- Variation of Magnetic declination -calculation of true bearings-Determination of included angles from the given bearings and vice versa in compass traverse - Plotting of closed traverse-closing error and adjustments by Bowditch graphical method - Precautions in using a Compass-Errors in Compass Surveying.

4.0 Levelling

Levelling – Types of levelling instruments – component parts of a dumpy level and their functions – Definitions of important terms used in Levelling – level surface, level line, plumb line, horizontal line, axis of telescope, line of collimation, back sight, fore sight, intermediate sight, station and change point – Temporary adjustments of a dumpy level – types of Levelling Staves - Bench marks – different types of bench marks - Booking of readings in field book – Determination of Reduced levels by height of instrument and Rise and Fall methods – Comparison of methods – Problems-Missing Entry - Calculations-Problems - Classification of Levelling – detailed description of profile levelling and reciprocal levelling – Problems on Reciprocal levelling - Errors due to curvature and refraction and combined correction – problems - Contouring – contour, contour interval and horizontal equivalent – Characteristics of contours – methods of contouring – Block contouring – Radial contouring – interpolation of contours – uses of Contour maps – tracing of contour gradient or alignment of a hill road – Marking alignment of roads, railways and canals - Fundamental lines of dumpy level and their relations – Permanent adjustments of a dumpy level (Two peg method without problems)

5.0 Minor instruments

Purpose of Minor instruments- Various minor instruments- Uses of Abney Level, Pentagraph and Electronic Planimeter .

REFERENCE BOOKS :

- | | | |
|-------------------------------|---|----------------------------------|
| 1) Dr. B.C.Punmia, | : | Surveying - I & II |
| 2) S.K. Husain | : | Surveying |
| 3) P Kanetkar | : | Surveying and levelling - I & II |
| 4) A.V.R.J. Sharma and Kamala | : | Surveying - I & II |
| 5) Dr.C.Venkat Ramaiah | : | Text book of surveying |

MODEL BLUE PRINT

S. No.	Chapter name	Periods allocated	Weightage of Marks allotted	Marks wise distribution of weightage				Periods wise distribution of weightage				CO'S MAPPED
				R	U	Ap	An	R	U	Ap	An	
1	Introduction to surveying	5	11	3	0	0	0	1	0	0	0	CO1
2	Chain Surveying	21	17	3	3	16	0	1	1	2	0	CO2
3	Compass Surveying	21	25	3	3	8	0	1	1	1	0	CO3
4	Levelling	40	14	6	6	16	0	2	2	2	0	CO4
5	Minor Instruments	03	3	3	0	0	0	1	0	0	0	CO5
NOTE: HIGHER ORDER QUESTION FROM ANY OR COMBINATION UNITS 2,3,4			10	0	0	0	10	0	0	0	1	CO2, CO3, CO4
TOTAL			80	18	12	40	10	6	4	5	1	

R-remember
U-Understanding
Ap-Application
An-Analysing

Table specifying the scope of syllabus to be covered for Unit Test-I, Unit Test-II & Unit Test -III

Unit Test	Learning Outcomes to be covered
Unit Test – I	From 1.1 to 2.10
Unit Test – II	From 3.1 to 4.3
Unit Test – III	From 4.4 to 5.3

Model Paper for Unit Test-I :

**State Board of Technical Education and Training, A.P.
Diploma in Civil Engineering (DCE)
First Year :C-106 SURVEYING-I**

Time: 90 Minutes

Unit Test –I

Maximum Marks : 40

PART- A

16 Marks

Instructions :

- (i) Answer all questions
 - (ii) First question carries FOUR marks, each question of remaining carries THREE marks.
- 1.(a) Marine survey deals with water bodies for the purpose of navigation, water supply, harbour works etc. (TRUE/FALSE) (CO1)
 - (b) Number of links in 30 m metric chain is _____ (CO2)
 - (c) Optical square is used to establish _____ (CO2)
 - (d) The method performed to set out perpendicular using chain alone is _____ (CO2)
 2. State fundamental principles of surveying. (CO1)
 3. Define plane surveying and Geodetic surveying. (CO1)
 4. Define Base line, check line and Tie line. (CO2)
 5. What are the instruments used in chain surveying. (CO2)

PART- B

3 x 8 = 24 Marks

Instructions :

- (i) Answer all questions
 - (ii) Each question carries EIGHT marks
 - (iii) Answer should be comprehensive and the criterion for valuation is the content but not the length of the answer.
6. (A) Plot the following cross staff survey of a field ABCDEFG and calculate its area in hectares. (CO2)

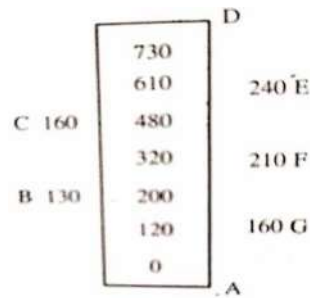

(OR)

(B) Explain with sketches the method of direct and indirect ranging.. (CO2)

7. (A) A chain was tested before starting the survey and was found to be 20m. At the end of the survey it was tested again and found to be 20.12m. Area of the plan of the field drawn to a scale of 10mm=6m, was 5040sqm. Find the true area of the field in Square meters.(CO2)

(OR)

(B) A survey line ABDE intersects a building between B and D. To overcome the obstacle a perpendicular BC 90m long, is set out at B. From C, two lines CD and CE are set out at angles 45° and 60° respectively with CB. Find the lengths CD and CE such that points D and E fall on the prolongation of line AB. Also find the obstructed distance BD. (CO2)

8. (A) The following perpendicular offsets were taken from a survey to a hedge. (CO2)

Distance (m)	0	5	10	15	20	30	40	55	70
Offset (m)	3.29	4.05	6.23	5.75	4.76	5.26	4.32	3.92	2.91

Find the area between the survey line and the hedge by Trapezoidal rule and Simpsons rule.

(OR)

(B) What are the types of obstacle in chaining? Explain by any two methods how chaining is continued when a river comes across a chain line. (CO2)

-OOo-

Model Paper for Unit Test-II:
State Board of Technical Education and Training, A.P.
Diploma in Civil Engineering (DCE)
First Year :C-106 SURVEYING-I

Time: 90 Minutes

Unit Test –II

Maximum Marks : 40

PART- A

16 Marks

Instructions :

- (i) Answer all questions
 - (ii) First question carries FOUR marks, each question of remaining carries THREE marks.
- 1.(a) Whole circle bearing of a line is $354^{\circ}30'$ then Quadrantal bearing is _____ (CO3)
 - (b) Line joining points of same declination is called _____ (CO3)
 - (c) The arithmetical check formula in the case of Height of Instrument method of reduction of levels is _____ (CO4)
 - (d) The readings taken on a staff at which instrument shifted is called _____ (CO4)
 2. Calculate back bearings for the following fore bearing of the lines. (CO3)
 - (i) $310^{\circ}30'$ (ii) $145^{\circ}15'$ (iii) $210^{\circ}30'$
 3. Convert following Quadrantal bearings into whole circle bearings: (CO3)
 - (i) N $45^{\circ}15'$ E (ii) S $45^{\circ}20'$ E (iii) S $10^{\circ}45'$ W
 4. Define the following terms: (CO4)
 - (i) Back sight (ii) Fore sight (iii) Change point
 5. Define (i) Level surface (ii) Datum. (CO4)

PART- B

3 x 8 = 24 Marks

Instructions :

- (i) Answer all questions
- (ii) Each question carries EIGHT marks
- (iii) Answer should be comprehensive and the criterion for valuation is the content but not the length of the answer.

6. (A) Draw the neat sketch of prismatic compass and explain the function of parts. (CO3)

(OR)

- (B) The bearings of the sides of the traverse ABCDEA are given below. Sketch and compute interior angles of the traverse. (CO3)

Line	FB	BB
AB	$110^{\circ}15'$	$290^{\circ}15'$
BC	$35^{\circ}15'$	$215^{\circ}15'$
CD	$276^{\circ}30'$	$96^{\circ}30'$
DE	$195^{\circ}30'$	$15^{\circ}30'$
EA	$132^{\circ}15'$	$312^{\circ}15'$

7. (A) The following bearings were observed in a closed traverse ABCDA. Identify the stations effected by local attraction and correct it. (CO3)

Line	FB	BB
AB	46°10'	226°10'
BC	119°20'	298°40'
CD	169°30'	351°10'
DA	280°20'	99°20'

(OR)

- (B).What are the instrumental errors that normally occur in doing survey with prismatic compass? How they can be avoided. (CO3)

8. (A) Draw the neat sketch of Dumpy level and mention its parts (CO4)

(OR)

- (B) The following observations were observed on a continuously sloping ground:

0.605, 1.105, 1.895, 2.300, 0.950, 1.340, 1.975, 0.760, 1.785, 0.905 and 1.235.

The R.L of first point was 120.650.

- Enter the readings properly into the levelling field book proforma. Reduce the levels by Height of Instrument method and Rise and Fall method. Apply the arithmetical check. (CO4)

-oOo-

Model Paper for Unit Test-III:
State Board of Technical Education and Training, A.P.
Diploma in Civil Engineering (DCE)
First Year :C-106 SURVEYING-I

Time: 90 Minutes

Unit Test –III

Maximum Marks : 40

PART- A

16 Marks

Instructions :

- (i) Answer all questions
 - (ii) First question carries FOUR marks, each question of remaining carries THREE marks.
- 1.(a) B.S = 1.525 and R.L of B.M=+100.000 then Height of the Instrument is _____ (CO4)
 - (b) Line joining the points of same elevation is called _____ (CO4)
 - (c) Level difference between any two consecutive contours is called _____ (CO4)
 - (d) Pentagraph is used to _____ (CO5)
 2. Define (i) Contour interval and (ii) Contour gradient. (CO4)
 3. What is reciprocal levelling? When it is resorted to? (CO4)
 4. State any three characteristics of contours. (CO4)
 5. State any three uses of Abney level. (CO5)

PART- B

3 x 8 = 24 Marks

Instructions :

- (i) Answer all questions
- (ii) Each question carries EIGHT marks
- (iii) Answer should be comprehensive and the criterion for valuation is the content but not the length of the answer.

6. (A) The following reciprocal levels were taken with Dumpy level. (CO4)

Instrument at	Staff readings on		Remarks
	A	B	
A	1.156	2.597	AB = 1200m RL of A = +625.555
B	0.987	2.418	

Find (i) True level difference between A and B (ii) RL of B (iii) The combined correction for curvature and refraction and (iv) The error in collimation adjustment of the level.

(OR)

(B) Describe briefly the effect of curvature and refraction in levelling. Derive an expression for curvature correction, refraction correction and for combined correction. (CO4)

7. (A) The following is the page of a level book entered in pencil. Some of the entries got erased, and have been marked with crosses. Calculate the missing readings. (CO4)

Station	BS	IS	FS	Rise	Fall	RL
1	x					150.000
2		2.457		0.827		X
3		2.400		x		X
4	2.697		x		x	148.070
5	x		2.051			148.716
6		2.500				149.784
7		2.896				149.388
8		x			0.124	X
9			2.672			149.612

(OR)

(B) The following observations were taken during the testing of a dumpy level. (CO4)

Instrument Near to	Staff Readings on	
	A	B
A	1.275	2.005
B	1.040	1.660

Is the instrument in adjustment? To what reading should the line of collimation be adjusted when the instrument is near to B.

8. (A) Work out the difference in levels between points A and B if curvature and refraction effects are taken into account in the following case: (CO4)

Level is setup over A, and the staff held at B

RL of A = 150.000,

Height of the Instrument at A = 1.000

Reading of staff at B = 1.800

Distance AB = 500m

(OR)

(B) The areas enclosed by the contours in a lake are as follows: (CO4)

Contour (m)	270	275	280	285	290
Area (sqm)	2050	8400	16300	24600	31500

Calculate the volume of water between the contours 270m and 290m by (i) Trapezoidal formula
(ii) Prismoidal formula.

Model paper for End Exam:

MODEL PAPER – BOARD DIPLOMA EXAMINATION, (C-20)

DCE—FIRST YEAR EXAMINATION

SURVEYING-I (C-106)

Time: 3 hours]

[Total Marks: 80

PART—A

3×10=30 Marks

Instructions: (1) Answer **all** questions.

(2) Each question carries **three** marks.

(3) Answers should be brief and straight to the point and shall not exceed *five* simple sentence

- 1) State the Classification of Survey based on the Instruments used. (CO1)
- 2) What are the equipment used in Chain surveying?. (CO2)
- 3) What is an Offset? Distinguish between perpendicular and oblique offsets. (CO2)
- 4) Distinguish between Magnetic bearing and True bearing of a Survey line. (CO3)
- 5) Convert the following Whole Circle Bearings to Quandrantal Bearings.
(i) $25^{\circ}30'$ (ii) $165^{\circ}20'$ (iii) $312^{\circ}45'$ (CO3)
- 6) Define (i) Back Sight (ii) Fore Sight (iii) Intermediate Sight (CO4)
- 7) State the relationship between the Fundamental Lines of a Level. (CO4)
- 8) Write the differences between Height of Inst and Rise and Fall methods. (CO4)
- 9) State any three uses of Contour Maps. (CO4)
- 10) State any three uses of Abney Level. (CO5)

PART – B

8 x 5 marks = 40 marks

Answer either (a) or (b) from each questions from Part-B

- 11) (A) Explain with a sketch the process of Indirect Ranging. (CO2)

(OR)

- (B) From the following Cross Staff Survey of Field ABCDEFG and calculate its Area in Hectares. The readings are in meters. (CO2)

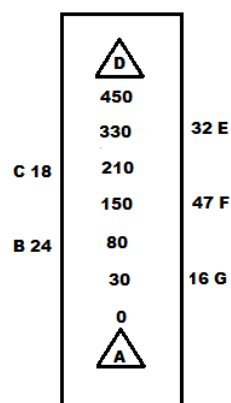

12) (A) Explain the operations involved in chaining on Sloping ground (CO2)

(OR)

(B) Calculate the area enclosed between the chain line and the irregular boundary using Trapezoidal and Simpson's rule from the data given. (CO2)

Distance(m)	0	3	6	9	12	15	18	21	24
Offset (m)	0.48	1.36	1.57	3.1	2.65	2.05	1.98	1.56	0.85

13) (A) Draw a neat sketch of a Prismatic Compass and explain the function of the parts. (CO3)

(OR)

(B) The following bearings were observed in running a compass traverse.(CO3)

Line	F.B.	B.B.	Line	F.B.	B.B.
AB	45°15'	225°15'	BC	123°15'	303°15'
CD	181°00'	1°00'	DA	289°30'	109°30'

Calculate the interior angles of the traverse)

14) (A) State Various methods of Levelling and Describe the method of Reciprocal levelling.

(CO4)

(OR)

(B) While performing Reciprocal levelling between two points P and Q on opposite banks of a Pond, the level was setup near P and the staff readings on P and Q were 1.985 and 3.525 m respectively. The Level was then moved near to Q and the respective Staff readings on P and Q were 1.645 and 2.975. Find the true difference in levels of P and Q. Also find the RL of Q, if RL of P is 325.00 m. (CO4)

15) (A) The following readings were observed successfully with a levelling Instrument. The Instrument was shifted after 5th and 11th readings. Draw up a page of Level book and determine the R.L. of various points if R.L. of first reading was 158.340 m. Use Height of Collimation method.

0.475, 1.015, 1.625, 3.185, 3.925, 0.565, 1.275, 1.805, 2.495, 3.410, 3.785, 1.745, 0.615 and 0.580. (CO4)

(OR)

(B) Explain Contouring by i) Method of Squares and ii) Cross-Section Method.(CO4)

PART – C

Question No.16 is compulsory and carries 10 marks

10 x1 = 10 marks

16) Explain the method of conducting Profile levelling and write its application in civil engineering works. (CO4)

Course Code	Course Title	No. of Periods per Week	Total No. of Periods	Marks for Formative Assessment	Marks for Summative Assessment
C-107	ENGINEERING DRAWING	06	180	40	60

S.No	Major Topics	Periods	COs Mapped
1	Importance of Engineering Drawing	01	CO1
2	Engineering Drawing Instruments	05	CO1
3	Free hand lettering & Numbering	06	CO1
4	Dimensioning Practice	09	CO1
5	Geometrical constructions	21	CO2
6	Projections of points, Lines, Planes & Solids	21	CO3
7	Auxiliary views	6	CO3
8	Sections of Solids	27	CO3
9	Orthographic Projections	33	CO3
10	Isometric Views	30	CO4
11	Development of surfaces	21	CO5
	Total	180	

COURSE OBJECTIVES:

Upon completion of the course the student shall able to	
Course Objectives	understand the basic graphic skills and use them in preparation of engineering drawings, their reading and interpretation

COURSE OUTCOMES:

Course Outcomes	CO1	C-107.1	Practice the use of engineering drawing instruments and Familiarise with the conventions to be followed in engineering drawing as per BIS
	CO2	C-107.2	Construct the i) basic geometrical constructions ii) engineering curves
	CO3	C-107.3	Visualise and draw the orthographic projections of i) Points ii) Lines iii) Regular Planes iv) Regular Solids V) Sections of Regular Solids .
	CO4	C-107.4	Visualise and draw the isometric views of objects .
	CO5	C-107.5	Draw the developments of surfaces of regular solids and thereby the components used in daily applications

LEARNING OUTCOMES:

Learning Outcomes	<p>1.0 Understand the basic concepts of Engineering Drawing</p> <p>1.1 State the importance of drawing as an engineering communication medium</p> <p>1.2 State the necessity of B.I.S. Code of practice for Engineering Drawing.</p> <p>1.3 Explain the linkages between Engineering drawing and other subjects of Mechanical Engineering</p> <p>2.0 Use of Engineering Drawing Instruments</p> <p>2.1 Select the correct instruments to draw the different lines / curves</p> <p>2.2 Use correct grade of pencil to draw different types of lines and for different purposes</p> <p>2.3 Select and use appropriate scales for a given application.</p> <p>2.4 Identify different drawing sheet sizes as per I.S. and Standard Lay- outs.</p> <p>2.5 Prepare Title block as per B.I.S. Specifications.</p> <p>2.6 Identify the steps to be taken to keep the drawing clean and tidy.</p> <p>Drawing Plate 1: (Having two exercises)</p> <p>3.0 Write Free Hand Lettering and Numbers</p> <p>3.1 Write titles using sloping lettering and numerals of 7mm, 10mm and 14mm height</p> <p>3.2 Write titles using vertical lettering and numerals of 7mm, 10mm and 14mm height</p> <p>3.3 Select suitable sizes of lettering for different layouts and applications</p> <p>Drawing plate 2: (Having 5 to 6 exercises)</p>
--------------------------	---

4.0 Understand Dimensioning Practice

4.2 Acquaint with the conventions, notations, rules and methods of dimensioning in engineering drawing as per the B.I.S.

4.5 Dimension a given drawing using standard notations and desired system of dimensioning.

Drawing Plate 3: (Having 08 to 10 exercises)

5.0 Apply Principles of Geometric Constructions

5.1 Practice the basic geometric constructions like

- i) dividing a line into equal parts
- ii) exterior and interior tangents to the given two circles
- iii) tangent arcs to two given lines and arcs

5.2 Draw any regular polygon using general method when

- i) side length is given
- ii) inscribing circle radius is given
- iii) describing circle radius is given

5.2 Draw the conics using general and special methods,

5.3 Draw the engineering curves like i) involute

- ii) cycloid
- iii) helix

5.4 Identify the applications of the above constructions in engineering practice.

Drawing Plate -4: Having problems up to construction of polygon

Drawing Plate -5: Having problems of construction of conics

Drawing Plate -6: Having problems of construction of involutes, cycloid and helix

6.0 Apply Principles of Projection of points, lines, planes & auxiliary planes

6.1 Explain the basic principles of the orthographic projections

6.2 Visualise and draw the projection of a point with respect to reference planes (HP & VP)

6.3 Visualise and draw the projections of straight lines with respect to two reference planes (up to lines parallel to one plane and inclined to other plane)

6.4 Visualise and draw the projections of planes (up to planes perpendicular to one plane and inclined to other plane)

6.5 Identify the need of Auxiliary views for a given engineering drawing.

6.5 Draw the auxiliary views of a given engineering component

Drawing Plate -7: Having problems up to projection of points and Lines (15 exercises)

Drawing Plate -8: Having problems of projection of planes (6 exercises)

Drawing Plate -9: Having problems on auxiliary planes (Having 4 exercises)

	<p>7.0 Draw the Projections of Solids</p> <p>7.1 Visualise and draw the projections of solids (up to axis of solids parallel to one plane and inclined to other plane)</p> <p>Drawing plate No.10: Having problems of projection of solids (10 exercises)</p> <p>8.0 Appreciate the need of Sectional Views</p> <p>8.1 Identify the need to draw sectional views.</p> <p>8.4 Differentiate between true shape and apparent shape of section</p> <p>8.5 Draw sectional views and true sections of regular solids by applying the principles of hatching.</p> <p>Drawing Plate–11: Having problems of section of solids (6 exercises)</p> <p>9.0 Apply principles of orthographic projection</p> <p>9.1 Draw the orthographic views of an object from its pictorial drawing.</p> <p>9.2 Draw the minimum number of views needed to represent a given object fully.</p> <p>Drawing Plate 12 : (Having 10 to 12 exercises)</p> <p>10.0 Prepare pictorial drawings</p> <p>10.1 identify the need of pictorial drawings.</p> <p>10.2 Differentiate between isometric scale and true scale.</p> <p>10.3 Prepare Isometric views for the given orthographic drawings.</p> <p>Drawing plate 13: (Having 10 to 12 exercises)</p> <p>11.0 Interpret Development of surfaces of different solids</p> <p>11.1 State the need for preparing development drawing.</p> <p>11.2 Draw the development of simple engineering objects (cubes, prisms, cylinders, cones, pyramid) using parallel line and radial line method.</p> <p>11.3 Prepare development of surface of engineering components like i) funnel ii) 90° elbow</p> <p>Drawing plate No. 14: (Having 05 exercises)</p>
--	--

PO-CO Mapping

Course Code : C-107	Course Title ENGINEERING DRAWING Number of Course Outcomes: 06			No. of Periods 180	
POs	Mapped with CO No.	CO Periods addressing PO in Column 1		Level (1,2,3)	Remarks
		No	%		
PO1	CO1, CO2, CO3, CO4, CO5	12	7	1	>40% Level.3 (Highly addressed) 25% - 40% Level.2 (Moderately addressed)
PO2	CO1, CO2, CO3, CO4, CO5	12	7	1	
PO3	CO1, CO2, CO3, CO4, CO5	72	40	3	
PO4	CO1, CO2, CO3, CO4, CO5	72	40	3	
PO5					5% - 25% Level.1 (Low addressed)
PO6	CO1, CO2, CO3, CO4, CO5	12	6	1	<5% Not addressed
PO7					

CO-PO Mapping

CO No.	PO1	PO2	PO3	PO4	PO5	PO6	PO7	PSO1	PSO2	PSO3
CO1	2	2	3	3		2		1	2	2
CO2	2	3	3	3		2		1	2	2
CO3	3	2	3	3		3		1	2	2
CO4	3	2	3	3		3		2	2	2
CO5	3	2	3	3		3		2	2	2
Average	2.6	2.2	3	3		2.6		1.4	2	2

Note : The gaps in CO-PO mapping will be met by one or more appropriate activities from the following:

- (i) Assignments (ii) Tutorials (iii) Seminars (iv) Guest lectures (v) Group discussions (vi) Quiz (vii) Industrial visits (viii) Tech fests (ix) Mini project works (x) Library visits etc

Key competencies to be achieved by the student

S.No	Major topic	Key Competency
1.	Importance of Engineering Drawing	<ul style="list-style-type: none"> • Explain the linkages between Engineering drawing and other subjects of study in Diploma course.
2.	Engineering Drawing Instruments	<ul style="list-style-type: none"> • Select the correct instruments to draw various entities in different orientation
3.	Free hand lettering & Numbering	<ul style="list-style-type: none"> • Write titles using sloping and vertical lettering and numerals as per B.I.S (Bureau of Indian standards)
4.	Dimensioning Practice	<ul style="list-style-type: none"> • Dimension a given drawing using standard notations and desired system of dimensioning
5.	Geometrical construction	<ul style="list-style-type: none"> • Construct ellipse, parabola, rectangular hyperbola, involute, cycloid and helix from the given data.
6.	Projection of points, Lines, Planes & Solids	<ul style="list-style-type: none"> • Draw the projections of points, straight lines, planes & solids with respect to reference planes (HP& VP)
7.	Auxiliary views	<ul style="list-style-type: none"> • Draw the auxiliary views of a given Engineering component • Differentiate between Auxiliary view and apparent view
8.	Sections of Solids	<ul style="list-style-type: none"> • Differentiate between true shape and apparent shape of section • Apply principles of hatching. • Draw simple sections of regular solids
9.	Orthographic Projection	<ul style="list-style-type: none"> • Draw the minimum number of views needed to represent a given object fully.
10.	Pictorial Drawings	<ul style="list-style-type: none"> • Differentiate between isometric scale and true scale. • Draw the isometric views of given objects,.
11.	Development of surfaces	<ul style="list-style-type: none"> • Prepare development of Surface of regular solids and other components like i) funnel ii) 90⁰ elbow

COURSE CONTENT

NOTES:

1. **B.I.S Specification should invariably be followed in all the topics.**
2. **A-3 Size Drawing Sheets are to be used for all Drawing Practice Exercises.**

1.0 **The importance of Engineering Drawing**

Explanation of the scope and objectives of the subject of Engineering Drawing Its importance as a graphic communication -Need for preparing drawing as per standards – SP-46 –1988 – Mention B.I.S - Role of drawing in -engineering education – Link between Engineering drawing and other subjects of study.

2.0 **Engineering drawing Instruments**

Classifications: Basic Tools, tools for drawing straight lines, tools for curved lines, tools for measuring distances and special tools like mini drafter & drafting machine – Mentioning of names under each classification and their brief description -Scales: Recommended scales reduced & enlarged -Lines: Types of lines, selection of line thickness - Selection of Pencils - Sheet Sizes: A0, A1, A2, A3, A4, A5, Layout of drawing sheets in respect of A0, A1, A3 sizes, Sizes of the Title block and its contents - Care and maintenance of Drawing Sheet, Drawing plate: Lay out of sheet – as per SP-46-1988 to a suitable scale -Simple Exercises on the use of Drawing Instruments. Importance of Title Block.

3.0 **Free hand lettering & numbering**

Importance of lettering – Types of lettering -Guide Lines for Lettering - Practicing of letters & numbers of given sizes (7mm, 10mm and 14mm) -Advantages of single stroke or simple style of lettering - Use of lettering stencils

4.0 **Dimensioning practice**

Purpose of engineering Drawing, Need of B.I.S code in dimensioning -Shape description of an Engineering object -Definition of Dimensioning size description -Location of features, surface finish, fully dimensioned Drawing -Notations or tools of dimensioning, dimension line extension line, leader line, arrows, symbols, number and notes, rules to be observed in the use of above tools -Placing dimensions: Aligned system and unidirectional system (SP-46-1988)-Arrangement of dimensions Chain, parallel, combined progressive, and dimensioning by co-ordinate methods-The rules for dimensioning standard, features “Circles (holes) arcs, angles, tapers, chamfers, and dimension of narrow spaces.

5.0 **Geometric Construction**

Division of a line: to divide a straight line into given number of equal parts -Construction of tangent lines: to draw interior and exterior tangents to two circles of given radii and centre distance -Construction of tangent arcs: -i) To draw tangent arc of given radius to touch two lines inclined at given angle (acute, right and obtuse angles)-ii)Tangent arc of given radius touching a circle or an arc and a given line-iii)Tangent arcs of radius R, touching two given circles internally and externally -Construction of polygon: construction of any regular polygon by general method for given side length, inscribing circle radius and describing/superscribing circle radius - Conics: Explanation of Ellipse, Parabola, Hyperbola, as sections of a double cone and a loci of a moving point, Eccentricity of above curves – Their Engg. Applicationsviz.,Projectiles, reflectors, P-V Diagram of a Hyperbolic process - Construction of any conic section of given eccentricity by general method -Construction of

ellipse by concentric circles method, Oblong Method and Arcs of circles method - Construction of parabola by rectangle method and Tangent method -Construction of rectangular hyperbola - General Curves: Involute, Cycloid and Helix, explanations as locus of a moving point -their engineering application, viz., Gear tooth profile, screw threads, springs etc. –their construction

6.0 Projection of points, lines and planes & solids

Classification of projections, Observer, Object, Projectors, Projection, Reference Planes, Reference Line, Various angles of projections –Differences between first angle and third angle projections -Projections of points in different quadrants -Projections of straight line – (a) Parallel to both the planes (b) Perpendicular to one of the planes (c) Inclined to one plane and parallel to other planes - Projections of regular planes - (a) Plane parallel to one of the reference planes - (b) Plane perpendicular to HP and inclined to VP and vice versa - Projections of regular solids - (a) Axis perpendicular to one of the planes (b) Axis parallel to VP and inclined to HP and vice versa.

7.0 Auxiliary views

Need for drawing auxiliary views -Explanation of the basic principles of drawing an auxiliary views explanation of reference plane and auxiliary plane -Partial auxiliary view.

8.0 Sections of Solids

Need for drawing sectional views – what is a sectional view - Hatching – Section of regular solids inclined to one plane and parallel to other plane

9.0 Orthographic Projections

Meaning of orthographic projection -Using a viewing box and a model – Number of views obtained on the six faces of the box, - Legible sketches of only 3 views for describing object - Concept of front view, top view, and side view sketching these views for a number of engg objects - Explanation of first angle projection. – Positioning of three views in First angle projection - Projection of points as a means of locating the corners of the surfaces of an object – Use of miter line in drawing a third view when other two views are given -Method of representing hidden lines -Selection of minimum number of views to describe an object fully.

10.0 Pictorial Drawings

Brief description of different types of pictorial drawing viz., Isometric, oblique, and Perspective and their use - Isometric drawings: Iso axis, angle between them, meaning of visual distortion in dimensions - Need for an isometric scale, difference between Isometric scale, and ordinary scale difference between Isometric view and Isometric projection - Isometric and non-Isometric lines -Isometric drawing of common features like rectangles, circular - shapes, non-isometric lines - Use of box and offset methods.

11.0 Development of Surfaces

Need for preparing development of surface with reference to sheet metal work-Concept of true length of a line with reference to its orthographic projection when the line is (i) parallel to the plane of projection (ii) inclined to one principal and parallel to the other - Development of simple solids like cubes, prisms, cylinders, cones, pyramid and truncation of these solids-Types of development: Parallel line and radial line development -Procedure of drawing development of funnels, 90° elbow pipes.

REFERENCE BOOKS:

1. P I Varghese : Engineering Graphics – (McGraw-hill)
2. Basant Agarwal & C.M Agarwal : Engineering Drawing - (McGraw-hill)
3. N.D.Bhatt : Engineering Drawing .
4. T.S.M. & S.S.M on “ Technical Drawing” : T.T.T.I., Madras.
5. SP-46-1998 : Bureau of Indian Standards.

MODEL BLUE PRINT

S. No	Major Topics	No. of periods	Weightage of marks	Marks wise Distribution of Weightage				Question wise Distribution of Weightage				CO's Mapped	
				R	U	Ap	An	R	U	Ap	An		
1	Importance of Engineering Drawing	01	-										CO1
2	Engineering Drawing Instruments	05	-										CO1
3	Free hand lettering & Numbering	06	5		5				1				CO1
4	Dimensioning Practice	09	5		5				1				CO1
5	Geometrical constructions	21	15		5	10			1	1			CO2
6	Projections of points, Lines, Planes & Solids	21	10			10				1			CO3
7	Auxiliary views	6	5		5				1				CO3
8	Sections of Solids	27	10			10				1			CO3
9	Orthographic Projections	33	10			10				1			CO3
10	Isometric Views	30	10			10				1			CO4
11	Development of surfaces	21	10			10				1			CO5
Total		180	80		20	60			4	6			

Note : Students have to write four out of six 10 marks questions.

Model Paper for End Examination:
MODEL PAPER – BOARD DIPLOMA EXAMINATION, (C-20)
DCE—FOURTH SEMESTER EXAMINATION
ENGINEERING DRAWING (C-107)

Time: 3 hours]

[Total Marks: 80

PART—A (5 X 4 = 20 Marks)

- Instructions:* (1) Answer all questions.
 (2) Each question carries five marks.
 (3) All dimensions are in mm.

1. Write the following in single-stroke vertical lettering of size 10 mm in capital letters: "CLEAN AND GREEN IS OUR PERFECT DREAM" (CO1)
2. Redraw the following figure to full-scale and dimension it according to SP : 46—1988 by using aligned system: (CO1)

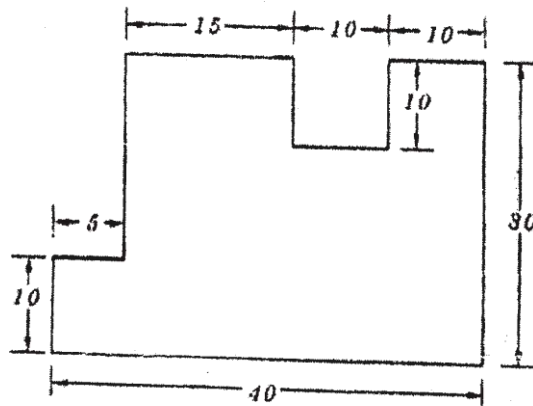

3. Draw a common external tangent to two circles of radii 25 mm and 20 mm. The distance between the centres of circles is 75 mm. (CO2)
4. Draw the auxiliary view of the object shown below: (CO3)

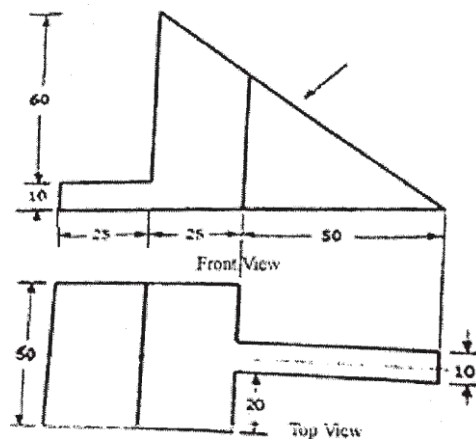

PART—B (10 x 4=40)

Instructions: (1) Answer *any* four questions.

(2) Each question carries ten marks.

(3) All dimensions are in mm.

5. Draw a helix of cylinder diameter 50 mm and pitch 70 mm. (CO2)

6. Draw the top view and front view of a circular plane, if the surface of the plane is perpendicular to HP and inclined at 30° to VP. (CO3)

7. A hexagonal pyramid of base side 30 mm and axis 75 mm long is resting on its base in HP having a base side parallel to VP. It is cut by a section plane which is inclined at 30° to HP, perpendicular to VP and passing through a point on the axis at a distance of 35 mm from the vertex. Draw its sectional front view and sectional top view. (CO3)

8. Draw the Front view, top view and side view of the given figure: (CO3)

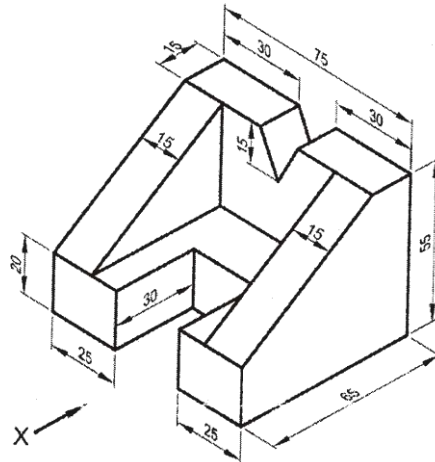

9. Draw the isometric view of the object for the views given below.

(CO4)

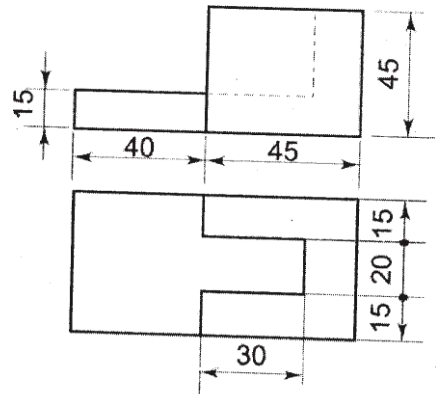

10. A right circular cone of diameter 50 mm and axis 75 mm long is resting on its base in HP. It is cut by a section plane which is perpendicular to VP, inclined at 60° to HP and passing through a point on the axis at a height of 40 mm from the base. Draw the surface development of the bottom position of truncated cone. (CO5)

Course Code	Course Title	No. of Periods per Week	Total No. of Periods	Marks for Formative Assessment	Marks for Summative Assessment
C-108	SURVEYING-I PRACTICE & PLOTTING	06	180	40	60

S. No.	Major Topics	No. of Periods	COs MAPPED
1.	Chain surveying	42	CO1
2.	Compass Surveying	42	CO2
3.	Levelling	60	CO3
4.	Plotting	36	CO1,CO2,CO3
	Total	180	

COURSE OBJECTIVES:

Course Objectives	(i)	Enhance knowledge about surveying instruments & methods adopted to carry out Field Survey with a professional approach.
	(ii)	Develop skills in using chain, tape, compass& Dumpy level

COURSE OUTCOMES:

Course Outcomes	CO1	C-108.1	Apply standard Practices to perform chain survey in the field and to plot from field data
	CO2	C-108.2	Apply Principles to Perform compass survey and plot from field data
	CO3	C-108.3	Conduct experiments on methods of levelling, Longitudinal and cross sectioning for the given alignment and analyse the data by Block levelling (contours) prepare the drawings.

<p>Learning Outcomes</p>	<p>1.0 Chain surveying</p> <ol style="list-style-type: none"> 1.1. Practice unfolding and folding a chain. 1.2. Perform direct ranging on level ground and measure the distance between two given stations and record the measurements in the field book. 1.3. Perform indirect ranging and measure the distance between two given stations when a high ground intervenes to prevent indivisibility of ends of line. 1.4. Set out a right angle to a given chain line by using chain only. 1.5. Set and measure offsets for a given chain line by 1.Perpendicular offsets and 2.Oblique offsets. 1.6. Perform triangulation survey of a given area with chain and cross staff and record all necessary details. 1.7. Calculate the area bounded by the given points by chain triangulation and compare the result with the area calculated from plotting. 1.8. Calculate the area bounded by the given points by chain and Cross staff compares the result with the area calculated from plotting. 1.9. Carry out chain survey to overcome obstacles like pond, building etc and plot the Survey from field book measurements. 1.10. Carry out chain traversing to survey an area bounded by more than three stations and plot the Survey from field book measurements. <p>2.0 Compass Survey</p> <ol style="list-style-type: none"> 2.1 Identify the parts of a prismatic Compass 2.2 Set up the compass at a station and carry out temporary adjustments. 2.3 Take bearings of two points from instrument station and calculate the included angle. 2.4 Perform an open traverse with Compass and Chain. 2.5 Perform a closed traverse with compass and chain. 2.7 Plot the closed traverse from field data and adjust for closing error by Bowditch rule. 2.8 Determine the area bounded by the given points by the method of Radiation. 2.9 Determine the distance between two accessible points involving single setting of the instrument. 2.10 Determine the distance between two inaccessible points involving setting of the instrument at two stations. <p>3.0 Levelling</p> <ol style="list-style-type: none"> 3.1 Identify the component parts of a dumpy level / Auto level and Study different types of levelling staves 3.2 Perform temporary adjustments of a dumpy level / Auto level for taking observations and Practice taking staff readings and recording them in level field book.
---------------------------------	---

	<p>3.3 Take staff readings for differential levelling and Compute the difference in elevation between two stations (take invert levels also)</p> <p>3.4 Determine the true difference in elevation between two far off stations by conducting reciprocal levelling</p> <p>3.5 Determine the collimation error of a dumpy level by conducting reciprocal levelling</p> <p>3.6 Conduct profile levelling along a route and compute the RLs at various stations</p> <p>3.7 Conduct profile levelling by taking cross sections across a route and compute the RLs at various stations</p> <p>3.8 Conduct profile levelling along a route by taking readings along both LS and CS and compute the RLs</p> <p>3.9 Conduct block levelling for the given area</p> <p>3.10 Locate the contour Points by direct (Radial) method in the field</p> <p>4.0 PLOTTING</p> <p>4.1 Understand the importance and relation between field work and plotting.</p>
--	---

PO-CO Mapping:

Course Code: C-108	Course Title: SURVEYING –II Practice&Plotting No. of COs: 3				No. of Periods: 180
POs	Mapped with CO Nos.	CO periods addressing PO in Col.1		Level (1,2,3)	Remarks
		No.	%		
1	1,2,3	47	26	2	>40% Level.3 (Highly addressed) 25% - 40% Level.2 (Moderately addressed) 5% - 25% Level.1 (Low addressed) <5% Not addressed
2	1,2,3	27	15	1	
3					
4	1,2,3	76	42	3	
5	1,2,3	10	6	1	
6	1,2,3	10	6	1	
7	1,2,3	10	5	1	

CO-PO Mapping:

CO No.	PO1	PO2	PO3	PO4	PO5	PO6	PO7	PSO1	PSO2	PSO3
CO1	2	2		2	2	2	2	2	2	2
CO2	2	3		2	2	2	2	2	2	2
CO3	3	2		3	3	3	2	2	2	2
Average	2.3	2.3		2.3	2.3	2.3	2	2	2	2

Note : The gaps in CO-PO mapping will be met by one or more appropriate activities from the following:

(i) Assignments (ii) Tutorials (iii) Seminars (iv) Guest lectures (v) Group discussions (vi) Quiz (vii) Industrial visits (viii) Tech fests (ix) Mini project works (x) Library visits etc

COURSE CONTENT

1.0 Chain Surveying

- a) Practice unfolding and folding of a chain.
- b) Ranging and chaining of lines on level ground and recording in field book to measure the distance between two stations.
- c) Chaining a line involving indirect ranging.
- d) Setting and measuring the offsets-Perpendicular and Oblique offsets
- e) Measurement of land areas –cross staff survey
- f) Chain triangulation around the building covering a small area with other details taking offsets and recording.
- g) Chain triangulation involving a road with other details taking offsets and recording.
- h) Chain traversing to survey an area bounded by more than three stations.

2.0 Compass Surveying

- a) Setting up the compass – observations of bearings
- b) Calculation of included angles from the observed bearings
- c) Traversing with prismatic compass and chain – open Traverse – Recording.
- d) Traversing with prismatic compass and chain- closed traverse - recording.
- e) Plotting the closed traverse from field data and adjust for closing error by Bowditch rule.
- f) Determination of the area bounded by the given points by the method of Radiation
- g) Determination of the distance between two accessible points involving single setting of the instrument
- h) Determination of the distance between two inaccessible points involving setting of the instrument at two stations.

3.0 Levelling

- a) Study of dumpy level, levelling staves – performing Temporary adjustments of level.
- b) Taking staff readings of various stations – booking of readings in level field book.
- c) Differential and Fly levelling – calculation of reducing levels by height of collimation and Rise & Fall methods (inverted levels also)
- d) Reciprocal levelling – True difference in elevation and collimation error.
- e) Profile levelling along a route by taking readings along both LS and CS and compute the RLs
- f) Contouring – block levelling and locating contour points by Radial method

4.0 Plotting

a) Conventional signs in Surveying	2 Exercises
b) Plotting of perpendicular and oblique i. offsets	1 Exercise
c) Plotting of land surveys – Chain i. and cross-staff Surveying – Calculation of areas	3 Exercises
d) Plotting of chain triangulation i. Surveying of small areas around Buildings.	2 Exercises
e) Chain traversing to survey an area bounded by i. more than three stations	2 Exercises
f) Plotting of closed traverse by a. Compass surveying – location of b. Details and adjusting error by c. Bow ditch method.	2 Exercises
g) Plotting of open traverse by Compass a. surveying and locating details	2 Exercises.
h) Compass survey by method of radiation- a. calculation of area	1 Exercise
i) Determination of the distance between a. two accessible points involving single b. setting of the instrument	1 Exercise
j) Determination of the distance between a. two inaccessible points involving setting b. of the instrument at two stations.	2 Exercises
k) Plotting of LS and CS	2 Exercises
l) Plotting of contours by Block levelling	2 Exercises

Total	24 Exercises

KEY competencies to be achieved by the student

S.NO.	Experiment Title	Key Competency
1	Field Exercises in Chain Surveying Ex 1.1 Ex 1.2 Ex 1.3 Ex 1.4 Ex 1.5 Ex 1.6 Ex.1.7 Ex.1.8 Ex 1.9 Ex 1.10	<ul style="list-style-type: none"> • Practice unfolding and folding a chain. • Perform direct ranging on level ground and measure the distance between two given stations and record the measurements in the field book. • Perform indirect ranging and measure the distance between two given stations when a high ground intervenes to prevent intervisibility of ends of line. • Set out a right angle to a given chain line by using chain only. • Set and measure offsets for a given chain line by 1. Perpendicular offsets and 2. Oblique offsets. • Perform triangulation survey of a given area with chain and cross staff and record all necessary details. • Calculate the area bounded by the given points by chain triangulation and compare the result with the area calculated from plotting. • Calculate the area bounded by the given points by chain and Cross staff compare the result with the area calculated from plotting. • Carry out chain survey to overcome obstacles like pond, building etc and plot the Survey from field book measurements. • Carry out chain traversing to survey an area bounded by more than three stations and plot the Survey from field book measurements.
2	Field Exercises in Compass Surveying Ex 1.1 Ex 1.2 Ex 1.3 Ex 1.4 Ex 1.5 Ex 1.6 Ex.1.7 Ex.1.8	<ul style="list-style-type: none"> • Identify the parts of a prismatic Compass • Set up the compass at a station and carry out temporary adjustments. • Take bearings of two points from instrument station and calculate the included angle. • Perform an open traverse with Compass and Chain. • Perform a closed traverse with compass and chain. • Plot the closed traverse from field data and adjust for closing error by Bowditch rule. • Determine the area bounded by the given points by the method of Radiation. • Determine the distance between two accessible points involving single setting of the instrument.

	Ex 1.9	<ul style="list-style-type: none"> • Determine the distance between two inaccessible points involving setting of the instrument at two stations.
4	<p>Field Exercises in Levelling</p> <p>Ex 1.1</p> <p>Ex 1.2</p> <p>Ex 1.3</p> <p>Ex 1.4</p> <p>Ex 1.5</p> <p>Ex 1.6</p> <p>Ex.1.7</p> <p>Ex.1.8</p> <p>Ex 1.9</p> <p>Ex 1.10</p>	<ul style="list-style-type: none"> • Identify the component parts of a dumpy level / Auto level and Study different types of levelling staves • Perform temporary adjustments of a dumpy level / Auto level for taking observations and Practice taking staff readings and recording them in level field book • Take staff readings for differential levelling and Compute the difference in elevation between two stations (take invert levels also) • Determine the true difference in elevation between two far off stations by conducting reciprocal levelling • Determine the collimation error of a dumpy level by conducting reciprocal levelling • Conduct profile levelling along a route and compute the RLs at various stations • Conduct profile levelling by taking cross sections across a route and compute the RLs at various stations • Conduct profile levelling along a route by taking readings along both LS and CS and compute the RLs • Conduct block levelling for the given area • Locate the contour Points by direct (Radial) method in the field

**PHYSICS LAB PRACTICE
(C-20 CURRIUCULUM COMMON TO ALL BRANCHES)**

Subject Code	Subject Title	Periods per week	Total periods per year
C-109 A	Physics Laboratory	03	45

TIMESCHEDULE

S.No	Name of the Experiment	No.of Periods
1.	Hands on practice on Vernier Calipers	03
2.	Hands on practice on Screw gauge	03
3.	Verification of Parallelogram law of forces and Triangle law of forces	03
4.	Simple pendulum	03
5.	Velocity of sound in air – (Resonance method)	03
6.	Focal length and Focal power of convex lens (Separate & Combination) (Single	03
7.	Refractive index of solid using traveling microscope	03
8.	Boyle's law verification	03
9.	Meter bridge	03
10.	Mapping of magnet lines of force and locate null points	03
	DEMONSTRATION EXPERIMENTS	
11.	Surface tension of liquid using traveling microscope	03
12.	Coefficient of viscosity by capillary method	03
	Revision	06
	Test	03
	Total	45

Objectives:

Upon completion of the course the student shall be able to

- 1.0 Practice with Vernier calipers to determine the volumes and areas of a cylinder and sphere and their comparison etc .
- 2.0 Practice with Screw gauge to determine thickness of a glass plate, cross sectional area of a wire and volumes of sphere and also their comparison etc
- 3.0 Verify the parallelogram law and Triangle law
- 4.0 Determine the value of acceleration due to gravity using Simple Pendulum
- 5.0 Determine the velocity of sound in air at room temperature and its value at zero degree centigrade.
- 6.0 Calculate the Focal length and focal power of convex lenses using distant object method , U-V method , U-V graph and $1/U - 1/V$ graph methods and their comparison.
- 7.0 Determine the refractive index of a solid using travelling microscope.
- 8.0 Verify the Boyle's law employing a Quill tube.
- 9.0 Determine the specific resistance of material of a wire using Meter Bridge.
- 10.0 Drawing magnetic lines of force under N-S and N-N methods and locate null points.

- 11.0 Determine the surface tension of a liquid using travelling Microscope (**Demo**)
- 12.0 Determine the viscosity of a liquid using capillary method (**Demo**)

Competencies and Key competencies to be achieved by the student

Name of the Experiment	Competencies	Key competencies
1. Hands on practice on Vernier Calipers(03)	<ul style="list-style-type: none"> • Find the Least count • Fix the specimen in posit • Read the scales • Calculate the physical quantities of given object 	<ul style="list-style-type: none"> • Read the scales • Calculate the requisite physical quantities of given objects
2. Hands on practice on Screw gauge(03)	<ul style="list-style-type: none"> • Find the Least count • Fix the specimen in posit • Read the scales • Calculate thickness of glass plate and cross section of wire and other quantities 	<ul style="list-style-type: none"> • Read the scales • Calculate thickness of given glass plate • Calculate cross section of wire and other quantities
3. Verification of Parallelogram law of forces and Triangle law of forces(03)	<ul style="list-style-type: none"> • Fix suitable weights • Note the positions of threads on drawing sheet • Find the angle at equilibrium point • Construct parallelogram • Compare the measured diagonal • Construct triangle • Find the length of sides • Compare the ratios 	<ul style="list-style-type: none"> • Find the angle at equilibrium point • Constructing parallelogram • Construct triangle • Compare the ratios of force and length
4. Simple pendulum(03)	<ul style="list-style-type: none"> • Fix the simple pendulum to the stand • Adjust the length of pendulum • Find the time for number of oscillations • Find the time period • Calculate the acceleration due to gravity • Draw I-T and I-T² graph 	<ul style="list-style-type: none"> • Find the time for number of oscillations • Find the time period • Calculate the acceleration due to gravity • Draw I-T and I-T² graph

<p>5. Velocity of sound in air –Resonance method (03)</p>	<ul style="list-style-type: none"> • Arrange the resonance apparatus • Adjust the reservoir level for booming sound • Find the first and second resonating lengths • Calculate velocity of sound 	<ul style="list-style-type: none"> • Adjust the reservoir level • Find the first and second resonating lengths • Calculate velocity of sound at room temperature • Calculate velocity of sound at 0⁰ C
<p>6. Focal length and Focal power of convex lens (Separate & Combination) (03)</p>	<ul style="list-style-type: none"> • Fix the object distance • Find the Image distance • Calculate the focal length and power of convex lens and combination of convex lenses • Draw u-v and 1/u – 1/v graphs 	<ul style="list-style-type: none"> • Calculate the focal length and power of convex lens • Draw u-v and 1/u – 1/v graphs
<p>7. Refractive index of solid using traveling microscope(03)</p>	<ul style="list-style-type: none"> • Find the least count of vernier on microscope • Place the graph paper below microscope • Read the scale • Calculate the refractive index of glass slab 	<ul style="list-style-type: none"> • Read the scale • Calculate the refractive index of glass slab
<p>8. Boyle’s law verification (03)</p>	<ul style="list-style-type: none"> • Note the atmospheric pressure • Fix the quill tube to retort stand • Find the length of air column • Find the pressure of enclosed air • Find and compare the calculated value P x l 	<ul style="list-style-type: none"> • Find the length of air column • Find the pressure of enclosed air • Find the value P x l

9. Meter bridge(03)	<ul style="list-style-type: none"> • Make the circuit connections • Find the balancing length • Calculate unknown resistance • Find the radius of wire • Calculate the specific resistance 	<ul style="list-style-type: none"> • Find the balancing length • Calculate unknown resistance • Calculate the specific resistance
10. Mapping of magnet lines of force(03)	<ul style="list-style-type: none"> • Draw magnetic meridian • Placed the bar magnet in NN and NS directions • Draw magnetic lines of force • Locate the neutral points along equatorial and axial lines 	<ul style="list-style-type: none"> • Draw magnetic lines of force • Locate the neutral points along equatorial and axial lines
11. Surface tension of liquid using traveling microscope(03)	<ul style="list-style-type: none"> • Find the least count of vernier on microscope • Focus the microscope to the lower meniscus & bent pin • Read the scale • Calculate height of liquid rise • Calculate the surface tension of water 	<ul style="list-style-type: none"> • Read the scale • Calculate height of liquid rise • Calculate the surface tension of water

12.. Coefficient of viscosity by capillary method(03)	<ul style="list-style-type: none"> • Find the least count of vernier • Fix the capillary tube to aspiratory bottle • Find the mass of collected water • Find the pressure head • Calculate rate of volume of liquid collected • Find the radius of capillary tube • Calculate the viscosity of water using capillary method 	<ul style="list-style-type: none"> • Find the pressure head • Calculate rate of volume of liquid collected • Find the radius of capillary tube • Calculate the viscosity of water
---	--	---

Scheme of Valuation for end Lab Practical Examination :

- A. Writing Aim, Apparatus, Formula, Graph, Precautions carries 10 (Ten) Marks
 B. For Drawing the table, taking Readings, Calculation work, Drawing the graph, finding result carries 15 (Fifteen) Marks
 C. Viva Voice 05 (Five) Marks
- Total 30 (Thirty) Marks**

➤ **Course outcomes**

Course Outcomes	CO1	Experiments with Vernier calipers, Screw gauge, Parallelogram law and Triangle law
	CO2	Experiments with Simple pendulum, Resonance apparatus (Velocity of sound in air)
	CO3	Experiments with Convex lens, Refractive index of solid by travelling microscope
	CO4	Experiments with quill tube (Boyles law verification), Meter bridge, Mapping of magnetic lines of force
	CO5	Experiments with Surface tension and Viscosity

➤ **COs-PO mapping strength (as per given table)**

	PO1	PO2	PO3	PO4	PO5	PO6	PO7
CO1	3			1	1	1	1
CO2	3	2	2		1		
CO3	3		2			1	2
CO4	3	2			2		
CO5	3		1	2		1	2

3 = strongly mapped 2= moderately mapped 1= slightly mapped

CHEMISTRY LABORATORY
(C-20 curriculum common to all Branches)

Subject Code	Subject Title	Periods per week	Total periods per year
C -109B	Chemistry Laboratory	03	45

CO1	Operate and practice volumetric apparatus and preparation of standard solution
CO2	Evaluate and judge the neutralization point in acid base titration
CO3	Evaluate the end point of reduction and oxidation reaction
CO4	Judge the stable end point of complex formation, stable precipitation
CO5	Judge operate and demonstrate and perform precise operations with instrument for investigation of water pollution parameters

PO CO mapping

Course code C-109B	Chemistry Laboratory No of Cos;5			No Of periods 45
POs	Mapped with CO No	CO periods addressing PO in Col 1 NO	Level 1,2,3	remarks
PO1	CO1,CO2,CO3, CO4,CO5	12	26.66	>40% level 3 (highly addressed) 25% to 40% level2(moderately addressed 5% to 25% level1 (Low addressed < 5%(not addressed)
PO2	CO1,CO2,CO3, CO4,CO5	9	20	
PO3				
PO4	CO1,CO2,CO3, CO4,CO5	12	26.66	
PO5	CO2,CO3, CO4,CO5	12	26.66	
PO6				
PO7				

COs-POs mapping strength (as per given table)

	PO1	PO2	PO3	PO4	PO5	PO6	PO7	PSO1	PSO2	PSO3
CO1	2	3		1				1		
CO2	2	3		2	2			1		
CO3	2	3		2	2			1		
CO4	2	3		2	2			1		
CO5	2	3		2	2			1		

3=strongly mapped

2= moderately mapped

1= slightly mapped

Note:

The gaps in CO and PO mapping will be achieved by one or more appropriate activities from the following:

i) Seminars ii) Tutorials iii) Guest Lectures iv) Assignments v) Quiz competitions vi) Industrial visit vii) Tech Fest viii) Mini project ix) Group discussions x) Virtual classes xi) Library visit for e-books

TIMESCHEDULE

S.No	Name of the Experiment	No.of Periods	Mapped with COs
1.	a) Recognition of chemical substances and solutions used in the laboratory by senses. b) Familiarization of methods for Volumetric analysis	03	CO1
2.	Preparation of Std Na_2CO_3 and making solutions of different dilution	03	CO1
3.	Estimation of HCl solution using Std. Na_2CO_3 solution	03	CO2
4.	Estimation of NaOH using Std. HCl solution	03	CO2
5.	Estimation of H_2SO_4 using Std. NaOH solution	03	CO2
6.	Estimation of Mohr's Salt using Std. KMnO_4	03	CO3
7.	Determination of acidity of water sample	03	CO2
8.	Determination of alkalinity of water sample	03	CO2
9.	Determination of total hardness of water using Std. EDTA solution	03	CO4
10.	Estimation of Chlorides present in water sample	03	CO4
11.	Estimation of Dissolved Oxygen(D.O) in water sample	03	CO5
12.	Determination of pH using pH meter	03	CO5
13.	Determination of conductivity of water and adjusting ionic strength	03	CO5
14.	Determination of turbidity of water	03	CO5
15.	Estimation of total solids present in water sample	03	CO5
	Total:	45	

Objectives:

Upon completion of the course the student shall be able to

- 1.0 Practice volumetric measurements (using pipettes, measuring jars, volumetric flask, burettes) and gravimetric measurements (using different types of balances), making dilutions, etc. To identify the chemical compounds and solutions by senses.
- 2.0 Practice making standard solutions with pre weighed salts and to make solutions of desired dilutions using appropriate techniques.
- 3.0 Conduct titrations adopting standard procedures and using Std. Na_2CO_3 solution for estimation of HCl
- 4.0 Conduct titrations adopting standard procedures and using Std. HCl solution for estimation of NaOH
- 5.0 Conduct titrations adopting standard procedures and using Std. NaOH solution for estimation of H_2SO_4

- 6.0 Conduct titrations adopting standard procedures and using Std. KMnO_4 solution for estimation of Mohr's Salt
- 7.0 Conduct titrations adopting standard procedures to determine the acidity of given samples of water (One ground water and one surface / tap water, and rain water if available)
- 8.0 Conduct titrations adopting standard procedures to determine the alkalinity of given samples of water (One ground water and one surface / tap water)
- 9.0 Conduct titrations adopting standard procedures to determine the total hardness of given samples of water (One ground water and one surface / tap water) using Std. EDTA solution
- 10.0 Conduct titrations adopting standard procedures to determine the chlorides present in the given samples of water and wastewater (One ground water and one surface / tap water)
- 11.0 Conduct the test using titrometric / electrometric method to determine Dissolved Oxygen (D.O) in given water samples (One sample from closed container and one from open container / tap water)
- 12.0 Conduct the test on given samples of water / solutions (like soft drinks, sewage, etc.) to determine their pH using standard pH meter
- 13.0 Conduct the test on given samples of water / solutions
 - a) To determine conductivity
 - b) To adjust the ionic strength of the sample to the desired value
- 14.0 Conduct the test on given samples of solutions (coloured and non coloured) to determine their turbidity in NTU
- 15.0 To determine the total solids present in given samples of water (One ground water and one surface / tap water)

Competencies and Key competencies to be achieved by the student

Name of the Experiment (No of Periods)	Competencies	Key competencies
Familiarization of methods for Volumetric analysis. Recognition of chemical substances And solutions (03)	-	--
Preparation of Std Na_2CO_3 and making solutions of different dilution(03)	<ul style="list-style-type: none"> ▪ Weighing the salt to the accuracy of .01 mg ▪ Measuring the water with volumetric flask, measuring jar, volumetric pipette and graduated pipette ▪ Making appropriate dilutions 	<ul style="list-style-type: none"> ▪ Weighing the salt to the accuracy of .01 mg ▪ Measuring the water with volumetric flask, measuring jar, volumetric pipette and graduated pipette ▪ Making appropriate dilutions
Estimation of HCl solution using Std. Na_2CO_3 solution (03)	<ul style="list-style-type: none"> ▪ Cleaning the glassware and rinsing with appropriate solutions 	<ul style="list-style-type: none"> ▪ Making standard solutions ▪ Measuring accurately the standard solutions and titrants ▪ Effectively Controlling the flow of the titrant ▪ Identifying the end point ▪ Making accurate observations
Estimation of NaOH using Std.HCl solution (03)	<ul style="list-style-type: none"> ▪ Making standard solutions 	
Estimation of H_2SO_4 using Std.NaOH solution (03)	<ul style="list-style-type: none"> ▪ Measuring accurately the standard solutions and titrants 	
Estimation of Mohr's Salt using Std. KMnO_4 (03)	<ul style="list-style-type: none"> ▪ Filling the burette with titrant ▪ Fixing the burette to the stand 	
Determination of acidity of water sample (03)	<ul style="list-style-type: none"> ▪ Effectively Controlling the flow of the titrant 	
Determination of alkalinity of water sample (03)	<ul style="list-style-type: none"> ▪ Identifying the end point 	
Determination of total hardness of water using Std. EDTA solution (03)	<ul style="list-style-type: none"> ▪ Making accurate observations 	
Estimation of Chlorides present in water sample (03)	<ul style="list-style-type: none"> ▪ Calculating the results 	
Estimation of Dissolved Oxygen(D.O) in water sample (By titration method) (03)		
Determination of pH using pH meter (03)	<ul style="list-style-type: none"> ▪ Familiarize with instrument ▪ Choose appropriate 'Mode' / 'Unit' 	<ul style="list-style-type: none"> ▪ Prepare standard solutions / buffers, etc. ▪ Standardize the

Determination of conductivity of water and adjusting ionic strength to required level (03)	<ul style="list-style-type: none"> ▪ Prepare standard solutions / buffers, etc. ▪ Standardize the instrument with appropriate standard solutions ▪ Plot the standard curve ▪ Make measurements accurately ▪ Follow Safety precautions 	<p>instrument with appropriate standard solutions</p> <ul style="list-style-type: none"> ▪ Plot the standard curve ▪ Make measurements accurately
Determination of turbidity of water (03)		
Estimation of total solids present in water sample (03)	<ul style="list-style-type: none"> ▪ Measuring the accurate volume and weight of sample ▪ Filtering and air drying without losing any filtrate ▪ Accurately weighing the filter paper, crucible and filtrate ▪ Drying the crucible in an oven 	<ul style="list-style-type: none"> ▪ Measuring the accurate volume and weight of sample ▪ Filtering and air drying without losing any filtrate ▪ Accurately weighing the filter paper, crucible and filtrate

SCHEME OF VALUATION

A) Writing Chemicals, apparatus ,principle and procedure	5M
B) Demonstrated competencies	20M
Making standard solutions	
Measuring accurately the standard solutions and titrants	
Effectively controlling the flow of the titrant	
Identifying the end point	
Making accurate observations	
C) Viva-voce	5M

Total	30M

Course code	Course Title	No. of Periods/Weeks	Total No. of periods	Marks for FA	Marks for SA
C-110 (common to all branches)	Computer Fundamentals Lab	3	90	40	60

Time schedule:

S.No.	Chapter/Unit Title	No. of sessions each of 3 periods duration	No.of Periods
1.	Computer hardware Basics	2	6
2.	Windows Operating System	2	6
3.	MS Word	8	24
4.	MS Excel	7	21
5.	MS PowerPoint	5	15
6.	Adobe Photoshop	6	18
Total periods		30	90

S.No.	Chapter/Unit Title	No.of Periods	CO's Mapped
1.	Computer hardware Basics	6	CO1
2.	Windows Operating System	6	CO1
3.	MS Word	24	CO2
4.	MS Excel	21	CO3
5.	MS PowerPoint	15	CO4
6.	Adobe Photoshop	18	CO5
Total periods		90	

Course Objectives	i)To know Hardware Basics ii)To familiarize operating systems iii)To use MS Office effectively to enable to students use these skills in future courses iv) To use Adobe Photoshop in image editing.
--------------------------	---

Course Outcomes	At the end of the course students will be able to		
	CO1	C-110.1	Identify hardware and software components
	CO2	C-110.2	Prepare documents with given specifications using word processing software
	CO3	C-110.3	Use Spread sheet software to make calculation and to draw various graphs / charts.
	CO4	C-110.4	Use Power point software to develop effective presentation for a given theme or topic.
	CO5	C-110.5	Edit digital or scanned images using Photoshop

CO-PO/PSO MATRIX

CO NO.	PO1	PO2	PO3	PO4	PO5	PO6	PO7	PSO1	PSO2	PSO3
C-110.1	3	3	3	3	3	3	3	3	2	3
C-110.2	3	3	3	3	3	3	3	3	2	3
C-110.3	3	3	3	3	3	3	3	3	2	3
C-110.4	3	3	3	3	3	3	3	3	2	3
C-110.5	3	3	3	3	3	3	3	3	2	3
Average	3	3	3	3	3	3	3	3	2	3

3=Strongly mapped , 2=moderately mapped, 1=slightly mapped

Learning Outcomes:**I. Computer Hardware Basics**

1. a).To Familiarize with Computer system and hardware connections
b).To Start and Shut down Computer correctly
c).To check the software details of the computer
2. To check the hardware present in your computer

II. Windows's operating system

3. To Explore Windows Desktop
4. Working with Files and Folders
5. Windows Accessories: Calculator – Notepad – WordPad – MS Paint

III. Practice with MS-WORD

6. To familiarize with Ribbon layout of MS Word
Home – Insert- Page layout – References – Review- View.
7. To practice Word Processing Basics
8. To practice Formatting techniques
9. To insert a table of required number of rows and columns
10. To insert Objects, Clipart and Hyperlinks
11. To use Mail Merge feature of MS Word
12. To use Equations and symbols features

IV.Practice with MS-EXCEL

13. To familiarize with MS-EXCEL layout
14. To access and enter data in the cells
15. To edit a spread sheet- Copy, Cut, Paste, and selecting Cells
16. To use built in functions and Formatting Data
17. To create Excel Functions, Filling Cells
18. To enter a Formula for automatic calculations
19. To sort and filter data in table.
20. To present data using Excel Graphs and Charts.
21. To develop lab reports of respective discipline.
22. To format a Worksheet in Excel, Page Setup and Print

V. Practice with MS-POWERPOINT

- 23. To familiarize with Ribbon layout features of PowerPoint 2007.
- 24. To create a simple PowerPoint Presentation
- 25. To set up a Master Slide in PowerPoint
- 26. To insert Text and Objects
- 27. To insert a Flow Charts
- 28. To insert a Table
- 29. To insert a Charts/Graphs
- 30. To insert video and audio
- 31. To practice Animating text and objects
- 32. To Review presentation

VI. Practice with Adobe Photoshop

- 33. To familiarize with standard toolbox
- 34. To edit a photograph.
- 35. To insert Borders around photograph.
- 36. To change Background of a Photograph.
- 37. To change colors of Photograph.
- 38. To prepare a cover page for the book in your subject area.
- 39. To adjust the brightness and contrast of the picture so that it gives an elegant look.
- 40. To type a word and apply the shadow emboss effects.

Key competencies:

Expt No	Name of Experiment	Competencies	Key competencies
1 (a).	To familiarize with Computer system and hardware connections	<ul style="list-style-type: none"> a. Identify the parts of a Computer system: i). CPU ii). Mother Board iii) Monitor iv) CD/DVD Drive v) Power Switch vi) Start Button vii) Reset Button b. Identify and connect various peripherals c. Identify and connect the cables used with computer system d. Identify various ports on CPU and connect Keyboard & Mouse 	Connect cables to external hardware and operate the computer
1 (b).	To Start and Shut down Computer correctly	<ul style="list-style-type: none"> a. Log in using the password b. Start and shut down the computer c. Use Mouse and Key Board 	<ul style="list-style-type: none"> a. Login and logout as per the standard procedure b. Operate mouse & Key Board
1 (c).	To Explore Windows Desktop	<ul style="list-style-type: none"> a. Familiarize with Start Menu, Taskbar, Icons and Shortcuts 	<ul style="list-style-type: none"> a. Access application programs using Start menu

		<ul style="list-style-type: none"> b. Access application programs using Start menu, Task manager c. Use Help support 	<ul style="list-style-type: none"> b. Use taskbar and Task manager
2.	To check the software details of the computer	<ul style="list-style-type: none"> a. Find the details of Operating System being used b. Find the details of Service Pack installed 	<ul style="list-style-type: none"> Access the properties of computer and find the details
3.	To check the hardware present in your computer	<ul style="list-style-type: none"> a. Find the CPU name and clock speed b. Find the details of RAM and Hard disk present c. Access Device manager using Control Panel and check the status of devices like mouse and key board d. Use My Computer to check the details of Hard drives and partitions e. Use the Taskbar 	<ul style="list-style-type: none"> a. Access device manager and find the details b. Type /Navigate the correct path and Select icon related to the details required
4.	Working with Files and Folders	<ul style="list-style-type: none"> a. Create folders and organizing files in different folders b. Use copy / paste move commands to organize files and folders 	<ul style="list-style-type: none"> a. Create files and folders Rename , arrange and search for the required folder/file
	Working with Files and Folders Continued....	<ul style="list-style-type: none"> c. Arrange icons – name wise, size, type, Modified d. Search a file or folder and find its path e. Create shortcut to files and folders (in other folders) on Desktop f. Familiarize with the use of My Documents g. Familiarize with the use of Recycle Bin 	<ul style="list-style-type: none"> b. Restore deleted files from Recycle bin

5.	To use Windows Accessories: Calculator – Notepad – WordPad – MS Paint	a.Familiarize with the use of Calculator b.Access Calculator using Run command c.Create Text Files using Notepad and WordPad and observe the difference in file size d.Use MS paint and create .jpeg, .bmp files using MS Paint	a. Use windows accessories and select correct text editor based on the situation. b. Use MS pain to create /Edit pictures and save in the required format.
6.	To familiarize with Ribbon layout of MS word. – Home – Insert- page layout- References-Review-View	a.Create/Open a document b.Use Save and Save as features c.Work on two Word documents simultaneously d.Choose correct Paper size and Printing options	a. Create a Document and name appropriately and save b. Set paper size and print options
7.	To practice Word Processing Basics	a.Typing text b.Keyboard usage c.Use mouse (Left click / Right click / Scroll) d.Use Keyboard shortcuts e.Use Find and Replace features in MS- word f. Use Undo and Redo Features g.Use spell check to correct Spellings and Grammar	a. Use key board and mouse to enter/edit text in the document. b. Use shortcuts c. Use spell check/ Grammar features for auto corrections.
8.	To practice Formatting techniques	a.Formatting Text b.Formatting Paragraphs c.Setting Tabs d.Formatting Pages e.The Styles of Word f. Insert bullets and numbers g.Themes and Templates h.Insert page numbers, header and footer	a. Format Text and paragraphs and use various text styles. b. Use bullets and numbers to create lists c. Use Templates /Themes d. Insert page numbers date, headers and footers
9.	To insert a table of required number of rows and columns	a.Edit the table by adding the fields – Deleting rows and columns –inserting sub table – marking borders. Merging and splitting of cells in a Table b.Changing the background colour of the table c.Use table design tools d.Use auto fit – fixed row/	a. Insert table in the word document and edit b. Use sort option for arranging data.

		<p>column height/length – Even distribution of rows / columns features</p> <p>e. Convert Text to table and Table to Text</p> <p>f. Use Sort feature of the Table to arrange data in ascending/descending order</p>	
10.	To Insert objects, clipart and Hyperlinks	<p>a. Create a 2-page document. & Insert hyperlinks and t Bookmarks.</p> <p>b. Create an organization chart</p> <p>c. Practice examples like preparing an Examination schedule notice with a hyperlink to Exam schedule table.</p>	<p>a. Insert hyperlinks & Bookmarks</p> <p>b. Create organization charts/flow charts</p>
11.	To Use Mail merge feature of MS Word	<p>a. Use mail merge to prepare individually addressed letters</p> <p>b. Use mail merge to print envelopes.</p>	Use Mail merge feature
12.	To use Equations and symbols features.	<p>a. Explore various symbols available in MS Word</p> <p>b. Insert a symbol in the text</p> <p>c. Insert mathematical equations in the document</p>	Enter Mathematical symbols and Equations in the word document
13.	To Practice with MS-EXCEL	<p>a. Open /create an MS Excel spreadsheet and familiarize with MS Excel 2007 layout like MS office Button-</p> <p>b. Use Quick Access Toolbar- Title Bar- Ribbon-Worksheets- Formula Bar-Status Bar</p>	<p>a. Familiarize with excel layout and use</p> <p>b. Use various features available in toolbar</p>
14.	To access and Enter data in the cells	<p>a. Move Around a Worksheets- Quick access -Select Cells</p> <p>b. Enter Data-Edit a Cell-Wrap Text-Delete a Cell Entry-Save a File-Close Excel</p>	<p>a. Access and select the required cells by various addressing methods</p> <p>b. Enter data and edit</p>
15.	To edit spread sheet Copy, Cut, Paste, and selecting cells	<p>a. Insert and Delete Columns and Rows-Create Borders-Merge and Center</p> <p>b. Add Background Color-Change the Font, Font Size, and Font Color</p> <p>c. Format text with Bold,</p>	Format the excel sheet

		Italicize, and Underline-Work with Long Text-Change a Column's Width	
16.	To use built in functions and Formatting Data	a. Perform Mathematical Calculations verify -AutoSum b. Perform Automatic Calculations-Align Cell Entries	Use built in functions in Excel
17.	To enter a Formula for automatic calculations	a. Enter formula b. Use Cell References in Formulae c. Use Automatic updating function of Excel Formulae d. Use Mathematical Operators in Formulae e. Use Excel Error Message and Help	Enter formula for automatic calculations
18.	To Create Excel Functions, Filling Cells	a. Use Reference Operators b. Work with sum, Sum if , Count and Count If Functions c. Fill Cells Automatically	a. Create Excel sheets involving cross references and equations b. Use the advanced functions for conditional calculations
19.	To sort and filter data in table	a. Sort data in multiple columns b. Sort data in a row c. Sort data using Custom order d. Filter data in work sheet	a. Refine the data in a worksheet and keep it organized b. Narrow a worksheet by selecting specific choice
20.	To Practice Excel Graphs and Charts	a. Produce an Excel Pie Chart b. Produce c. Excel Column Chart	a. Use data in Excel sheet to Create technical charts and graphs Produce Excel Line Graph b. Produce a Pictograph in Excel
21.	To develop lab reports of respective discipline	Create Lab reports using MS Word and Excel	a. Insert Practical subject name in Header and page numbers in Footer
22.	To format a Worksheet in Excel, page setup and print	a. Shade alternate rows of data b. Add currency and percentage symbols c. Change height of a row and width of a column d. Change data alignment e. Insert Headers and Footers	a. Format Excel sheet b. Insert headers & footers and print

		f. Set Print Options and Print	
23.	To familiarize with Ribbon layout & features of PowerPoint 2007.	Use various options in PowerPoint a. Home b. Insert c. Design d. Animation e. Slideshow f. View g. Review	Access required options in the tool bar
24.	To create a simple PowerPoint Presentation	a. Insert a New Slide into PowerPoint b. Change the Title of a PowerPoint Slide c. PowerPoint Bullets d. Add an Image to a PowerPoint Slide e. Add a Textbox to a PowerPoint slide	a. Create simple PowerPoint presentation with photographs/ClipArt and text boxes b. Use bullets option
25.	To Set up a Master Slide in PowerPoint and add notes	a. Create a PowerPoint Design Template b. Modify themes c. Switch between Slide master view and Normal view d. Format a Design Template Master Slide e. Add a Title Slide to a Design Template f. The Slide Show Footer in PowerPoint g. Add Notes to a PowerPoint Presentation	a. Setup Master slide and format b. Add notes
26.	To Insert Text and Objects	a. Insert Text and objects b. Set Indents and line spacing c. Insert pictures/ clipart d. Format pictures e. Insert shapes and word art f. Use 3d features g. Arrange objects	Insert Text and Objects Use 3d features
27.	To insert a Flow Chart / Organizational Charts	a. Create a Flow Chart in PowerPoint b. Group and Ungroup Shapes c. Use smart art	Create organizational charts and flow charts using smart art
28.	To insert a Table	a. PowerPoint Tables b. Format the Table Data c. Change Table Background d. Format Series Legend	Insert tables and format

29.	To insert a Charts/Graphs	<ul style="list-style-type: none"> a. Create 3D Bar Graphs in PowerPoint b. Work with the PowerPoint Datasheet c. Format a PowerPoint Chart Axis d. Format the Bars of a Chart e. Create PowerPoint Pie Charts f. Use Pie Chart Segments g. Create 2D Bar Charts in PowerPoint h. Format the 2D Chart e. Format a Chart Background 	Create charts and Bar graphs, Pie Charts and format.
30.	To Insert audio & video, Hyperlinks in a slide Add narration to the slide	<ul style="list-style-type: none"> a. Insert sounds in the slide and hide the audio symbol b. Adjust the volume in the settings c. Insert video file in the format supported by PowerPoint in a slide d. Use automatic and on click options e. Add narration to the slide f. Insert Hyperlinks 	<ul style="list-style-type: none"> a. Insert Sounds and Video in appropriate format. b. Add narration to the slide c. Use hyperlinks to switch to different slides and files
31.	To Practice Animation effects	<ul style="list-style-type: none"> a. Apply transitions to slides b. To explore and practice special animation effects like Entrance, Emphasis, Motion Paths & Exit 	Add animation effects
32.	Reviewing presentation	<ul style="list-style-type: none"> a. Checking spelling and grammar b. Previewing presentation c. Set up slide show d. Set up resolution e. Exercise with Rehearse Timings feature in PowerPoint f. Use PowerPoint Pen Tool during slide show g. Saving h. Printing presentation <ul style="list-style-type: none"> (a) Slides (b) Hand-out 	<ul style="list-style-type: none"> a. Use Spell check and Grammar feature b. Setup slide show c. Add timing to the slides d. Setup automatic slide show

33	To familiarize with standard toolbox	<ul style="list-style-type: none"> a. Open Adobe Photoshop b. Use various tools such as <ul style="list-style-type: none"> i. The Layer Tool ii. The Color & Swatches Tool iii. Custom Fonts & The Text Tool iv. Brush Tool v. The Select Tool vi. The Move Tool vii. The Zoom Tool viii. The Eraser ix. The Crop Tool x. The Fill Tool 	Open a photograph and save it in Photoshop
34	To edit a photograph	<ul style="list-style-type: none"> a. Use the Crop tool b. Trim edges c. Change the shape and size of a photo d. Remove the part of photograph including graphics and text 	a. Able to edit image by using corresponding tools.
35	To insert Borders around photograph	<ul style="list-style-type: none"> a. Start with a single background layer b. Bring the background forward c. Enlarge the canvas d. Create a border color e. Send the border color to the back f. Experiment with different colors 	Able to create a border or frame around an image to add visual interest to a photo
36	To change Background of a Photograph	<ul style="list-style-type: none"> a. open the foreground and background image b. Use different selection tools to paint over the image c. Copy background image and paste it on the foreground. d. Resize and/or drag the background image to reposition. e. In the Layers panel, drag the background layer below the foreground image layer. 	Able to swap background elements using the Select and Mask tool and layers.
37	To change colors of Photograph	<ul style="list-style-type: none"> a. Change colors using: <ul style="list-style-type: none"> i) Color Replacement tool ii) Hue/Saturation adjustment layer tool 	Able to control color saturation

38	To prepare a cover page for the book in subject area	<ul style="list-style-type: none"> a. open a file with height 500 and width 400 for the cover page. b. apply two different colors to work area by dividing it into two parts using Rectangle tool. c. Copy any picture and place it on work area→ resize it using free transform tool. d. Type text and apply color and style e. Apply effects using blended options 	Able to prepare cover page for the book
39	To adjust the brightness and contrast of picture to give an elegant look	<ul style="list-style-type: none"> a. open a file. b. Go to image→ adjustments→ Brightness/Contrast. c. adjust the brightness and contrast. d. Save the image. 	Able to control brightness/contrast.
40	To type a word and apply the shadow emboss effects	<ul style="list-style-type: none"> a. open a file b. Select the text tool and type text. c. Select the typed text go to layer→ layer style→ blended option→ drop shadow, inner shadow, bevel and emboss→ contour→ satin→ gradient overlay d. Save the image. 	Able to apply shadow emboss effects

Table specifying the scope of syllabus to be covered for unit tests

Unit Test	Learning outcomes to be covered
Unit test-1	From 1 to 8
Unit test-2	From 9 to 22
Unit test-3	From 23 to 40

I Year Internal Lab Examination
UNIT TEST - I
MODEL QUESTION PAPER
COMPUTER FUNDAMENTALS LAB

SCHEME: C-20
MAX MARKS:40

SUBJ CODE: C-110
Time:90Min

1. Identify the internal hardware components of a PC and assemble them.
2. Identify the external components or peripherals of a PC and connect them.
3. Identify the components on motherboard.
4. Perform the process of placing processor on CPU slot.
5. Perform the process of removing and placing the RAM in the corresponding slot.
6. Identify the CMOS battery and test whether it is working it or not.
7. Find details of following:
 - a) Operating System being used.
 - b) Processor name
 - c) RAM
 - d) Hard disk
8. Create a folder by your name, search a file or folder and find its path.
9. Draw the National Flag using MS Paint.
10. Create a word document that contains TEN names of your classmates (boys-5 & girls-5) and perform the following tasks:
 - a) Save the document to your desktop.
 - b) Sort the names in each list alphabetically.
 - c) Set line spacing to 1.15.
 - d) Use bullet points for the names in both lists separately.

I Year Internal Lab Examination
UNIT TEST - II
MODEL QUESTION PAPER
COMPUTER FUNDAMENTALS LAB

SCHEME: C-20
MAX MARKS:40

SUBJ CODE:CM-110
Time:90Min

1. Write individually addressed letters to your friends about the Republic Day celebration using Mail Merge.
2. Create a Word document about your college and insert page numbers in footer and College Name in header.
3. Create your class time table using Tables in MS Word.
4. Create a 2-page document about your College & insert hyperlinks for courses offered in the college and insert Bookmarks next to College Name.
5. Write individually addressed letters to your friends (at least 5 members) to intimate the External Examination time table using Mail Merge.
6. Write an equation $\frac{(x+y)^2}{(x-y)^2} = \frac{x^2+2xy+y^2}{x^2-2xy+y^2}$ in MS word.
7. Create the organizational structure of your college in MS Word.
8. Create a spreadsheet by totaling marks of 3 or more subjects, then calculate percentage and hence find grade based on boundary conditions of FIVE students:
 Grades O >= 90%, A >=80%, B >=70%, C >=60%, D >=50%, E >=40%, F <40%
9. Create a Excel spreadsheet for the following data, making sure that the cell marked with Category (A1) is pasted in cell A1 in the spreadsheet and perform the questions below.

Category (A1)	Product Name	Quantity	Inventory	Price per Unit	Total Price
Office Supplies	Binder	2	20	12.99	25.98
Office Supplies	Pencil	20	20	0.99	
Electronics	Samsung 4K Smart TV	1	5	399.00	
Electronics	Bluetooth Speakers	4	5	44.49	
Computers	Lenovo X230 12in Laptop	2	2	279.90	

- a). Change the format of the "Total Price" column to "Currency" format.
 - b) Calculate Total Price by writing formula.
 - c) Turn on filtering for the table.
 - d) Sort the table by column "Category" from A to Z.
10. Create a spreadsheet to calculate Cumulative monthly attendance for a period of Three months.

Year Internal Lab Examination
UNIT TEST - III
MODEL QUESTION PAPER
COMPUTER FUNDAMENTALS LAB

SCHEME: C-20

SUBJ CODE: COMMON-110

MAX MARKS:40

Time:90Min

1. Create a PowerPoint Presentation about your College in 5 slides only.
2. Create a PowerPoint Presentation on Computer Hardware in minimum 5 slides.
3. Create a PowerPoint Presentation on Computer Fundamentals with *Entrance, Emphasis* effects in minimum 5 slides.
4. Create a PowerPoint Presentation on any topic with special animation effects like *Entrance, Motion Paths & Exit*.
5. Resize the image using Photoshop.
6. Change the background of a Photograph.
7. Edit an image by using
 - a) Crop tool.
 - b) Resize the image
 - c) Save the new image with new name keeping original image as it is.
8. A Picture of two parrots (parrots.jpg) is given to you. Make anyone of one of the parrots in Black & White.
9. Convert a color image to monochrome and improve quality of photograph.
10. Copy three pictures and fit into the empty frames.

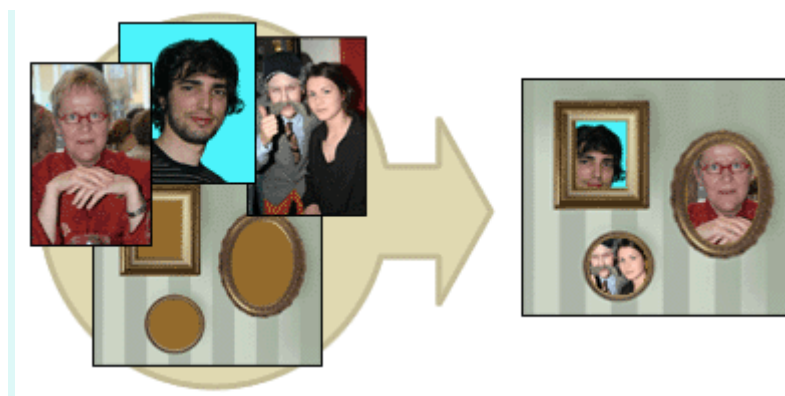

BOARD DIPLOMA EXAMINATIONS
DIPLOMA IN COMPUTER ENGINEERING
MODEL PRACTICAL QUESTION PAPER-YEAR END EXAM
COMPUTER FUNDAMENTALS LAB

SCHEME: C-20
MAX MARKS:60

SUBJ CODE:CM-110
TIME: 3HOURS

1. Identify the internal hardware components of a PC and assemble them.
2. Identify the external components or peripherals of a PC and connect them.
3. Write the procedure to create the files and folders
4. Write the procedure to access Calculator, Paint and Notepad application
5. Write the procedure to perform the following in MS Word
 - (a) Change the Font Size
 - (b) Change the Font Style
 - (c) Change the Text Size
6. Write the procedure to perform the following in MS Word
 - (a) Change the Font Color.
 - (b) Use Various Text Alignment Options.
 - (c) Format text in Bold, Italic and Underline.
7. Create the hierarchy of your family in MS Word.
8. Write the procedure to perform the following in MS Word:
 - (a) Insert a Table
 - (b) Add a Row
 - (c) Add a column
 - (d) Delete a Row
 - (e) Delete a column
9. Write the procedure to use Equation $\frac{(x+y)^2}{(x-y)^2} = \frac{x^2+2xy+y^2}{x^2-2xy+y^2}$ and Symbols.
10. Write the procedure to perform the following in MS Excel
 - (a) To Modify Column Width
 - (b) To Modify Row Height
 - (c) Format text in Bold, Italic, and Underline.
11. Write the procedure to create charts and Graphs in MS Excel.
12. Write the procedure to create simple Power Point Presentation on your college in Three slides.
13. Write the procedure to perform Animation on Text and Objects in your presentation.

14. Take a photographic image. Give a title for the image. Put the border. Write your names.
Write the Name of Institution and Place.
15. Prepare a cover page for the book in your subject area. Plan your own design.
16. You are given a picture of a flower and associated background (Extract.jpg). Extract the Flower only from that and organize it on a background. Select your own background for organization.
17. You are given a picture (BrightnessContrast.jpg). Adjust the brightness and contrast of the picture so that it gives an elegant look.
18. You are given a picture (position.jpg). Position the picture preferably on a plain background of a color of your choice - Positioning include rotation and scaling.
19. Remove the arrows and text from the given photographic image (Filename: photo.jpg).
20. Type a word; apply the following effects. Shadow Emboss.